



EVEKTOR - AEROTECHNIK a.s.

Letecka 1384
686 04 Kunovice
CZECH REPUBLIC

Tel.: +420572 537 111
Fax: +420 572 537 900
email: marketing@evektor.cz

AIRCRAFT OPERATING INSTRUCTIONS

FOR

SportStar^{MAX}

LIGHT SPORT AIRCRAFT

Serial number: **2016 1731**

Registration mark: **N19EV**

Document number: **SSM2008AOIUS**

Date of issue: **January 07, 2013**

This manual must be on the airplane board during operation. This manual contains information which must be provided to the pilot and also contains supplementary information provided by the airplane manufacturer - Evektor - Aerotechnik a.s.

This aircraft must be operated in compliance with the information and limitations stated in this manual.



CONTENTS

0. TECHNICAL INFORMATION

0.1	Log of Revisions	0-3
0.2	List of Effective Pages	0-5
0.3	AOI Sections.....	0-8



Intentionally left blank



AIRCRAFT OPERATING INSTRUCTIONS

Doc. No. SSM2008AOIUS

0.2 List of Effective Pages

Section	Page	Date	Section	Page	Date
-	Title page	-	2	2-1	01/07/2013
				2-2	01/07/2013
0	0-1	01/07/2013		2-3	01/07/2013
	0-2	01/07/2013		2-4	01/07/2013
	0-3	12/10/2014		2-5	12/10/2014
	0-4	01/07/2013		2-6	12/10/2014
	0-5	12/10/2014		2-7	01/07/2013
	0-6	01/07/2013		2-8	01/07/2013
	0-7	07/12/2013		2-9	01/07/2013
	0-8	01/07/2013		2-10	01/07/2013
				2-11	01/07/2013
				2-12	01/07/2013
				2-13	01/07/2013
				2-14	01/07/2013
1	1-1	07/12/2013			
	1-2	01/07/2013			
	1-3	07/12/2013	3	3-1	01/07/2013
	1-4	07/12/2013		3-2	01/07/2013
	1-5	07/12/2013		3-3	01/07/2013
	1-6	07/12/2013		3-4	01/07/2013
	1-7	07/12/2013		3-5	01/07/2013
	1-8	07/12/2013		3-6	01/07/2013
	1-9	07/12/2013		3-7	01/07/2013
	1-10	07/12/2013		3-8	01/07/2013
	1-11	07/12/2013		3-9	01/07/2013
	1-12	07/12/2013		3-10	01/07/2013



AIRCRAFT OPERATING INSTRUCTIONS

Doc. No. SSM2008AOIUS

Section	Page	Date	Section	Page	Date
4	4-1	01/07/2013	5	5-12	01/07/2013
	4-2	01/07/2013		5-13	01/07/2013
	4-3	01/07/2013		5-14	12/10/2014
	4-4	01/07/2013		5-15	01/07/2013
	4-5	01/07/2013		5-16	01/07/2013
	4-6	01/07/2013			
	4-7	01/07/2013			
	4-8	01/07/2013			
	4-9	01/07/2013		6	6-1
	4-10	01/07/2013	6-2		01/07/2013
	4-11	01/07/2013	6-3		01/07/2013
	4-12	01/07/2013	6-4		01/07/2013
	4-13	01/07/2013	6-5		01/07/2013
	4-14	01/07/2013	6-6		01/07/2013
	4-15	01/07/2013	6-7		01/07/2013
	4-16	01/07/2013	6-8		01/07/2013
	4-17	01/07/2013	6-9		01/07/2013
	4-18	01/07/2013	6-10		01/07/2013
		6-11	01/07/2013		
		6-12	01/07/2013		
		6-13	01/07/2013		
		6-14	01/07/2013		
5	5-1	01/07/2013			
	5-2	01/07/2013			
	5-3	01/07/2013			
	5-4	01/07/2013			
	5-5	01/07/2013			
	5-6	01/07/2013			
	5-7	01/07/2013			
	5-8	01/07/2013			
	5-9	01/07/2013			
	5-10	01/07/2013			
	5-11	01/07/2013			



0.3 AOI Sections

	Section
GENERAL	1
LIMITATIONS	2
EMERGENCY PROCEDURES	3
NORMAL PROCEDURES	4
PERFORMANCE	5
WEIGHT AND BALANCE	6
AIRPLANE AND SYSTEM DESCRIPTION	7
AIRPLANE HANDLING, SERVICING AND MAINTENANCE	8
SUPPLEMENTS	9



SECTION 1

1. GENERAL

1.1	Introduction	1-3
1.2	Certification basis	1-3
1.2.1	List of applicable standards	1-3
1.2.2	Data location	1-4
1.3	Warnings, cautions, notes	1-5
1.4	Descriptive data	1-6
1.4.1	Airplane description	1-6
1.4.2	Powerplant	1-6
1.4.3	Main technical data	1-7
1.4.4	Three-view drawing.....	1-8
1.5	Airplane Performance Specifications	1-9
1.6	Weight	1-9
1.7	Airspeeds and Performance	1-9
1.8	Fuel	1-10
1.9	Engine	1-10
1.10	Definitions and abbreviations	1-11



Intentionally left blank



AIRCRAFT OPERATING INSTRUCTIONS

Doc. No. SSM2008AOIUS

1.1 Introduction

PARTICIPANT'S RESPONSIBILITY

There are inherent risks in participating in aviation activities, these risks are significant, up to and potentially including death. Operators and passengers of recreational aviation aircraft, by participation, accept the risks inherent in such participation of which the ordinary prudent person is or should be aware. Pilots and passengers have a duty to exercise good judgment and act in a responsible manner while using the aircraft and to obey all oral or written warnings, or both, prior to and/or during use of the aircraft. This Aircraft Operating Instructions has been prepared to provide pilots and instructors with information for safe and efficient operation of the SportStar MAX airplane. It also contains supplementary information considered to be important by the airplane manufacturer.

1.2 Certification basis

SportStar MAX complies with the ASTM F2245 Standard Specification for Design and Performance of a Light Sport Airplane, issued by ASTM International Committee F37.

IFR version complies with FAR 91.205 requirements, as well as with F2245 Annex A3 Additional Requirements for Light Sport Airplanes Operated Under Instrument Flight Rules, as known till 1.1.2009.

1.2.1 List of applicable standards

List of applicable ASTM consensus standards is in compliance with FAA accepted ASTM consensus standards as amended:

- | | |
|-------|---|
| F2245 | Standard Specification for Design and Performance of a Light Sport Airplane |
| F2279 | Standard Practice for Quality Assurance in the Manufacture of Fixed Wing Light Sport Aircraft |
| F2295 | Standard Practice for Continued Operational Safety Monitoring of a Light Sport Aircraft |
| F2745 | Standard Specification for Required Product Information to be Provided with an Airplane |



AIRCRAFT OPERATING INSTRUCTIONS

Doc. No. SSM2008AOIUS

- F2339 Standard Practice for Design and Manufacture of Reciprocating Spark Ignition Engines for Light Sport Aircraft
- F2506 Standard Specification for Design and Testing of Fixed-Pitch or Ground Adjustable Light Sport Aircraft Propellers
- F2538 Standard Practice for Design and Manufacture of Reciprocating Compression Ignition Engines for Light Sport Aircraft
- F2746 Standard Specification for “Pilot’s Operating Handbook”
- F2316 Standard Specification for Airframe Emergency Parachutes for Light Sport Aircraft
- F2839 Standard Practice for Compliance Audits to ASTM Standards on Light Sport Aircraft

1.2.2 Data location

The certification documentation is available from the US General importer or airplane manufacturer on a request of competent aviation authority and/or Designated Airworthiness Representative.

Contact address:

Visit www.evektoraircraft.com for US importers

<p><u>Airplane Manufacturer:</u> Evektor - Aerotechnik, a.s. Letecká 1384 686 04 Kunovice Czech Republic tel.:+420 572 537 111 fax:+420 572 537 900 e-mail:marketing@evektor.cz</p>



AIRCRAFT OPERATING INSTRUCTIONS

Doc. No. SSM2008AOIUS

1.3 Warnings, cautions, notes

The following information apply to warnings, cautions and notes used in the Aircraft Operating Instructions:

WARNING

MEANS THAT NON-OBSERVATIONS OF THE CORRESPONDING PROCEDURE LEADS TO AN IMMEDIATE OR IMPORTANT DEGRADATION OF THE FLIGHT SAFETY.

CAUTION

MEANS THAT NON-OBSERVATIONS OF THE CORRESPONDING PROCEDURE LEADS TO A MINOR OR TO A MORE OR LESS LONG TERM DEGRADATION OF THE FLIGHT SAFETY.

NOTE

Draws the attention to any special item not directly related to safety but which is important or unusual.



1.4 Descriptive data

1.4.1 Airplane description

SportStar MAX airplane is a metal-composite low-wing monoplane of semimonocoque structure with two side by side seats and steerable nose wheel landing gear.

For further description see Section 7 - Airplane and system description.

1.4.2 Powerplant

The standard powerplant consists of ROTAX 912ULS (100 hp) engine and ground adjustable, 3-bladed, WOODCOMP KLASSIC 170/3/R propeller.

IFR version is fitted with certified ROTAX 912S2 engine and ground adjustable, 3-bladed, composite Warpdrive CF prop, with Nickel protection of blade leading edges.

For further description see Section 7 - Airplane and system description.

For particular engine and propeller type - see Section 9 - Supplements - Airplane description.



AIRCRAFT OPERATING INSTRUCTIONS

Doc. No. SSM2008AOIUS

1.4.3 Main technical data

Wing

Span	28.37 ft
Area	112.7 sq.ft
MAC depth	4.1 ft
Wing loading	11.71 lbs/sq.ft
Aileron - area	2.62 sq.ft
Flap - area	5.60 sq.ft

Fuselage

length	19.62 ft
width	3.55 ft
height	8.12 ft
cockpit canopy max. width	3.9 ft

Horizontal tail unit

Span	8.20 ft
HTU Area	20.88 sq.ft
Elevator area	8.40 sq.ft

Vertical tail unit

Height	4.21 ft
VTU Area	10.93 sq.ft
Rudder area	4.67 sq.ft

Landing gear

Wheel track	6.39 ft
Wheel base	4.43 ft
Nose and main landing gear wheel diameter	15 in



AIRCRAFT OPERATING INSTRUCTIONS

Doc. No. SSM2008AOIUS

1.4.4 Three-view drawing

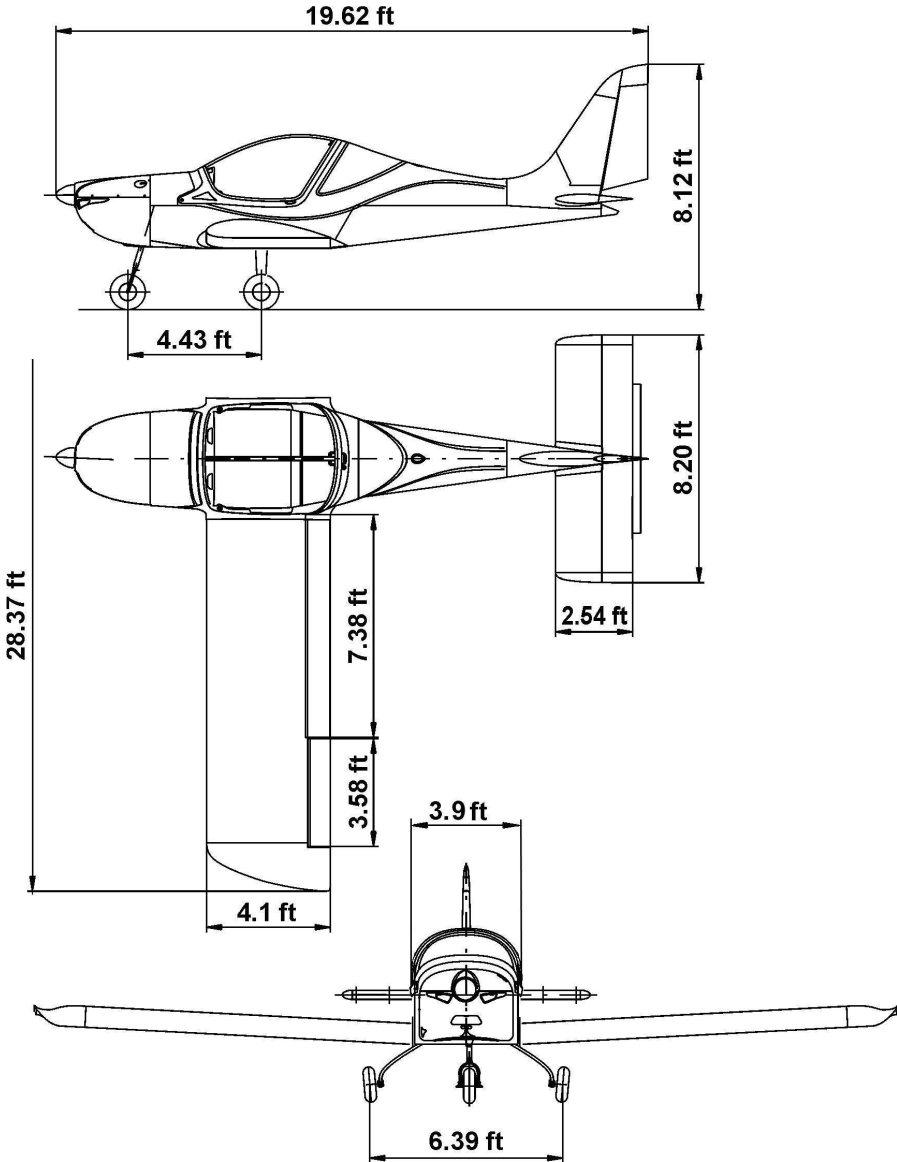

Figure 1-1



AIRCRAFT OPERATING INSTRUCTIONS

Doc. No. SSM2008AOIUS

1.5 Airplane Performance Specifications

1.6 Weight

Maximum take-off weight 600 kg

1.7 Airspeeds and Performance

Top speed (0 ft ISA, MTP) 106 KIAS

Cruise speed (2000 ft ISA, 75% MCP) 84 KIAS

Maximum range (2000 ft ISA, 75% MCP) 480 NM

Best rate-of-climb speed V_Y :

- Flaps retracted – 0° 65 KIAS
- Flaps in take-off position – 15° 57 KIAS

Best angle-of-climb speed V_X :

- Flaps retracted – 0° 56 KIAS
- Flaps in take-off position – 15° 54 KIAS

Stall speeds in horizontal flight:

- Flaps retracted – 0° 38 KIAS
- Flaps in take-off position – 15° 37 KIAS
- Flaps in landing position II – 50° 37 KIAS



1.8 Fuel

Total fuel capacity 31.7 U.S. gallons

Total usable fuel 31.2 U.S. gallons

Automotive gasoline with octane index min. RON 95 (or anti-knock index min. AKI 91) meets the following standards:

- Europe – EN 228 Super, EN 228 Super plus ¹⁾
- Canada – CAN/CGSB3.5 Quality 3
- USA – ASTM D4814
- Russia - R51866-2002

Aviation gasoline:

- AVGAS 100 LL aviation fuel according to ASTM D910.

AVGAS UL91 (unleaded) aviation fuel according to ASTM D7547.

1.9 Engine

Max. take-off power (5 minutes) 73.5 kW / 100HP
at 5800 RPM

Max. continuous power 69 kW / 93HP
at 5500 RPM



AIRCRAFT OPERATING INSTRUCTIONS

Doc. No. SSM2008AOIUS

1.10 Definitions and abbreviations

NOTE

The abbreviations on placards in the airplane cockpit, are printed in **BOLD CAPITAL LETTERS** in the text of this Aircraft Operating Instructions.

ACCU	accumulator
ALT ENC	encoding altimeter
ATC	air traffic control
bar	bar 1 bar = 100 kPa
BEACON	anti-collision beacon
°C	Celsius degree
CAS	calibrated airspeed
CLOCK	aircraft clock
ft	foot 1 ft = 0.305 m
GPS	global positioning system
HTU	horizontal tail unit
IAS	indicated airspeed
IC	intercom
IFR	instrument flight rules
ISA	international standard atmosphere
kg	kilogram
KIAS	indicated airspeed in knots
KCAS	calibrated airspeed in knots
mph	mile per hour
mph CAS	calibrated airspeed in miles per hour
km/h CAS	calibrated airspeed in km/h
kts	knots 1 kt = 1.852 km/h
litres	litre
lbs	pounds 1 lb = 0.45 kg
m	meter
MAC	mean aerodynamical chord
max.	maximum
min.	minimum or minute
mm	millimeter
m/s	meter per second
OAT	outside air temperature



AIRCRAFT OPERATING INSTRUCTIONS

Doc. No. SSM2008AOIUS

OFF position	system is switched off or control element is in off-
ON position	system is switched on or control element is in on-
Pa	pascal $1\text{Pa} = 1\text{N/m}^2$
PSI	pound per sq.in (1PSI = 6.89 kPa)
RPM	revolutions per minute
RWY	runway
sq.ft	foot squared
sq.m	meter squared
V_A	manoeuvring airspeed
V_{FE} position	maximum flap extended speed - flaps in 50°
VFR	visibility flight rules
V_{LOF}	airplane lift-off speed
V-METER	voltmeter
V_{NE}	never exceed speed
V_{NO}	maximum structural cruising speed
V_{SO}	stall speed with wing flaps in 50° position
V_{S1}	stall speed with wing flaps in 0° position
VTU	vertical tail unit
V_X	best angle-of-climb speed
V_Y	best rate-of-climb speed
XPDR	transponder



SECTION 2

2. LIMITATIONS

2.1	Introduction	2-3
2.2	Airspeed	2-3
2.3	Airspeed indicator marking	2-4
2.4	Powerplant.....	2-5
2.5	Powerplant instrument marking.....	2-6
2.6	Miscellaneous instrument marking.....	2-6
2.7	Weight.....	2-6
2.8	Centre of gravity.....	2-6
2.9	Approved manoeuvres	2-7
2.10	Manoeuvring load factors.....	2-7
2.11	Flight crew	2-7
2.12	Kinds of operation	2-8
2.13	Fuel	2-9
2.14	Oil.....	2-10
2.15	Maximum number of passengers	2-10
2.16	Other limitations.....	2-10
2.17	Limitation placards	2-11



Intentionally left blank



AIRCRAFT OPERATING INSTRUCTIONS

Doc. No. SSM2008AOIUS

2.1 Introduction

Section 2 contains operation limitation, instrument marking and basic placards necessary for safe operation of airplane and its engine, standard systems and equipment.

Limitation for optional systems and equipment are stated in section 9 - Supplements.

2.2 Airspeed

Airspeed limitations and their meaning for operation are stated in the table below:

Speed		KIAS	mph IAS	Meaning
V _{NE}	Never exceed speed	146	168	Do not exceed this speed in any operation.
V _{NO}	Maximum structural cruising speed	115	132	Do not exceed this speed, with exception of flight in smooth air, and even then only with increased caution.
V _A	Manoeuvring speed	90	106	Do not make full or abrupt control movement above this speed, because under certain conditions the aircraft may be overstressed by full control movement.
V _{FE}	Maximum flap extended speed	70	81	Do not exceed this speed with the given flap setting.



2.3 Airspeed indicator marking

Airspeed indicator markings and their color-code significance are shown in the table below:

Marking	Range		Meaning
	KIAS	mph IAS	
Red line	37	44	V_{S0} at maximum weight (flaps in landing position 50°)
White arc	37 - 70	44 – 81	Operating range with extended flaps. Lower limit- V_{S0} at maximum weight (flaps 50°) Upper limit - V_{FE}
Green arc	38 - 115	49 – 132	Normal operation range Lower limit - V_{S1} at maximum weight (flaps 0°) Upper limit - V_{NO}
Yellow arc	115 - 146	132 - 168	Manoeuvres must be conducted with caution and only in smooth air
Red line	146	168	Maximum speed for all operations - V_{NE} .



AIRCRAFT OPERATING INSTRUCTIONS

Doc. No. SSM2008AOIUS

2.4 Powerplant

Engine manufacturer:	Bombardier-Rotax GMBH	
Engine type:	ROTAX 912 ULS (S2 for IFR version)	
Power:	maximum take-off	73.5 kW / 100 HP
	maximum continuous	69 kW / 95 HP
Engine speed:	maximum take-off	5800 RPM max. 5 minutes
	maximum continuous	5500 RPM
	idle	1400 RPM
Coolant temperature:	maximum	248 °F
Oil temperature:	maximum	266 °F
	optimum operation	190 - 230 °F
Oil pressure:	maximum	102 PSI
	minimum	12 PSI
	optimum operation	29 - 73 PSI
Fuel pressure:	minimum	2.2 PSI
Fuel grades:	see 2.13,	
Oil grades:	see 2.14,	
Reducer gear ratio:	2.43 : 1	
Propeller:	Standardly installed:	IFR version:
Prop manufacturer:	WOODCOMP s.r.o.	Warpdrive
Propeller type:	KLASSIC 170/3/R	Warpdrive CF
	3 blade	Nickel protection of blade leading edges
	composite	3-bladed, composite
	ground adjustable	Ground adjustable
Propeller diameter:	68 in	68 in
Maximum prop speed:	2600 RPM	2600 RPM

NOTE

If installed a different propeller type - see section 9 - Supplements for propeller limitations.



2.5 Powerplant instrument marking

The colour-code of instruments is shown in the following table:

Instrument	Units	Red line	Green arc	Yellow arc	Red line
		Lower limit	Normal operation range	Caution range	Upper limit
RPM indicator	RPM	-	1400 - 5500	5500 - 5800	5800
Oil temperature indicator	°F	-	190 - 230	120 - 190 230 - 266	266
Oil pressure indicator	PSI	12	29 - 73	12 - 29 73 - 102	102
Coolant temperature	°F	-	194 - 230	-	248

2.6 Miscellaneous instrument marking

There are not other instruments with colour marking.

2.7 Weight

Empty weight (average equipment)	740 lbs ± 2 %
Maximum take-off weight	1320 lbs
Maximum landing weight	1320 lbs
Maximum weight in baggage compartment	55 lbs

WARNING

DO NOT EXCEED MAXIMUM WEIGHTS! THEIR EXCEEDING LEADS TO AIRPLANE OVERLOADING AND TO DEGRADATION OF FLIGHT CHARACTERISTICS AND DETERIORATION OF MANOEUVRABILITY.

2.8 Centre of gravity

Empty airplane C.G. position (standard equipment)	20 ± 2 %MAC
---	-------------



AIRCRAFT OPERATING INSTRUCTIONS

Doc. No. SSM2008AOIUS

Operating C.G. range

20 to 34 %MAC

Reference datum is the wing leading edge.

2.9 Approved manoeuvres

SportStar MAX airplane is approved to perform the following manoeuvres:

- steep turns up to bank angle of 60°
- climbing turns
- lazy eights
- stalls (except for steep stalls)
- normal flight manoeuvres

WARNING

AEROBATICS AS WELL AS INTENTIONAL SPINS ARE PROHIBITED !

2.10 Manoeuvring load factors

Maximum positive load factor

4.0

Maximum negative load factor

-2.0

2.11 Flight crew

Minimum crew

1 pilot

Minimum weight of crew

121 lbs

Maximum weight of crew acc. to chapter 6.

WARNING

DO NOT EXCEED MAXIMUM WEIGHTS! THEIR EXCEEDING LEADS TO AIRPLANE OVERLOADING AND TO DEGRADATION OF FLIGHT CHARACTERISTICS AND DETERIORATION OF MANOEUVRABILITY.



2.12 Kinds of operation

The airplane is standardly approved for VFR daylight flights.

WARNING

NIGHT FLIGHTS ACCORDING TO VFR, FLIGHTS ACCORDING TO IFR (BY INSTRUMENTS) ARE APPROVED ONLY WHEN INSTRUMENTATION REQUIRED FOR SUCH FLIGHTS IS INSTALLED AND FLIGHT PERFORMED BY A PILOT WITH APPROPRIATE RATING!

NOT AUTHORIZED FOR FLIGHT INTO KNOWN OR FORECAST POSSIBLE ICING CONDITIONS.

NOT AUTHORIZED FOR FLIGHT WITHIN 25 MILES OF KNOWN LIGHTNING OR THUNDERSTORMS.

Instruments and equipment for Day VFR flights:

- 1 Airspeed indicator (the color marking according to par. 2.3)
- 1 Sensitive barometric altimeter
- 1 Magnetic compass
- 1 Fuel gauge indicator
- 1 Oil temperature indicator
- 1 Oil pressure indicator
- 1 Cylinder head temperature indicator
- 1 Engine speed indicator
- 1 Safety harness for every used seat

Instruments and equipment for Night VFR flights:

F 2245 Annex 2 LSA to be flown at night

Instruments and equipment for IFR flights:

FAR 91.205 and

F2245 Annex 3 Additional Requirements for Light Sport Airplanes Operated Under Instrument Flight Rules, as proposed till 1.1.2009.

Refer to Supplement IFR to this standard Aircraft Operating Instructions

CAUTION

ADDITIONAL EQUIPMENT NECESSARY FOR AIRPLANE OPERATION IS GIVEN IN APPROPRIATE OPERATION REGULATION OF AIRPLANE OPERATOR'S COUNTRY.



AIRCRAFT OPERATING INSTRUCTIONS

Doc. No. SSM2008AOIUS

2.13 Fuel

The following fuels can be used :

Usage / Description		
912 UL / A / F		912 ULS / S
MOGAS		
European standard	EN 228 Normal ¹⁾	
	EN 228 Super ¹⁾	EN 228 Super ²⁾
	EN 228 Super plus ¹⁾	EN 228 Super plus ²⁾
Canadian standard	CAN/CGSB3.5 Quality 1 ³⁾	CAN/CGSB3.5 Quality 3 ⁴⁾
US standard	ASTM D4814	ASTM D4814
AVGAS		
US standard	AVGAS 100 LL (ASTM D910)	AVGAS 100 LL (ASTM D910)

¹⁾ min. ROZ 90

²⁾ min. ROZ 95

³⁾ min. AKI* 87

⁴⁾ min. AKI 91

AVGAS 100LL places greater stress on the valve seats due to its high lead content and forms increased deposits in the combustion chamber and lead sediments in the oil system. Thus it should only be used in case of problems with vapor lock or when other types of gasoline are unavailable.

■ **CAUTION:** Use only fuel suitable for the respective climatic zone.

◆ **NOTE:** Risk of vapour formation if using winter fuel for summer operation.

■ **CAUTION:** Obey the latest edition of Service Instruction SI-912-016 for the selection of the correct fuel.

Fuel tank volume (each)	15.85 U.S. gallons
Total	31.7 U.S. gallons
Usable fuel	31.2 U.S. gallons
Unusable fuel	0.5 U.S. gallons (0.25 US gal per tank)



NOTE

It is not recommended to fully tank the fuel tanks. Due to fuel thermal expansion keep about 2.11U.S. gallons of free space in the tank to prevent fuel bleed through the vents in the wing tips thus preventing environmental contamination. This should be adhered especially when cold fuel from an underground tank is tanked.

2.14 Oil

Performance classification SF, SG according to API

Oil volume:

- minimum 0.53 U.S. gallons
- maximum 0.79 U.S. gallons

2.15 Maximum number of passengers

Maximum number of passengers including pilot 2

2.16 Other limitations

SMOKING IS PROHIBITED on the airplane board.

PASSENGER NOTICE

This aircraft conforms to ASTM Consensus Standards of airworthiness developed and maintained by the aviation community under ASTM Technical Committee F37.

PASSENGER WARNING !

This aircraft was manufactured in accordance with Light Sport Aircraft airworthiness standards and does not conform to standard category airworthiness requirements.



AIRCRAFT OPERATING INSTRUCTIONS

Doc. No. SSM2008AOIUS

2.17 Limitation placards

The following placards are located on the instrument panel:



**BEFORE TAKE-OFF PUSH CANOPY HANDLE UP
TO CHECK CANOPY FULL CLOSING**

**WARNING
ASI AND ALT ON EFIS ARE INFORMATIVE ONLY!
SEE ANALOGUE INSTRUMENTS.**

**FUEL QUANTITY INDICATION IS ACCURATE
ONLY IN LEVEL FLIGHT ATTITUDE**

The following placards are located on the the tilting canopy:

**PASSENGER NOTICE:
THIS AIRCRAFT CONFORMS TO ASTM
CONSENSUS STANDARDS OF AIRWORTHINESS
DEVELOPED AND MAINTAINED BY THE
AVIATION COMMUNITY UNDER ASTM
TECHNICAL COMMITTEE F37.**

**PASSENGER WARNING!
THIS AIRCRAFT WAS MANUFACTURED IN
ACCORDANCE WITH LIGHT SPORT AIRCRAFT
AIRWORTHINESS STANDARDS AND DOES NOT
CONFORM TO STANDARD CATEGORY
AIRWORTHINESS REQUIREMENTS.**

This placard is located on the top of fixed rear canopy:

**CANOPY IS UNLOCKED IF A LATCH
IS VISIBLE UNDER THE GLASS**



Note: for painted top of the rear glass the latch is visible when looking sideways from under the painted area.

These placards are located on the tip-up canopy close to rear guide pins:

**CAUTION !
FINGERS OFF
WHEN CLOSING
THE CANOPY!**



AIRCRAFT OPERATING INSTRUCTIONS

Doc. No. SSM2008AOIUS

The following placard is located in the baggage compartment:

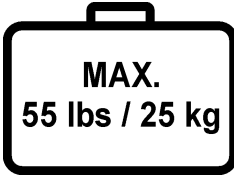

The following placard is located behind the baggage compartment:



It prohibits use of that place for additional stowage due to airplane aft C.G. limit.



AIRCRAFT OPERATING INSTRUCTIONS

Doc. No. SSM2008AOIUS

The following placards are located on sides of the tip-up canopy:

Day VFR airplane

This Light Sport Aircraft has been approved only for VFR day flights under no icing conditions.

Or (Night VFR airplane)

This Light Sport Aircraft has been approved only for day/night VFR flights under no icing conditions.

or (IFR airplane)

This Light Sport Aircraft has been approved by the Manufacturer for IFR flights with the following limitations:
Not authorized for IFR flights into known or forecast possible icing conditions.
Not authorized for IFR flights within 25 miles of known lightning or thunderstorms.

and (all versions)

Aerobatics and intentional spins are prohibited!	
AIRSPEED IAS	
Never exceed	146 kts
Manoeuvring	90 kts
Max. Flap Extended	70 kts
Stalling	37 kts
ENGINE SPEED	
Max. Take-off (max. 5 min.)	5800 rpm
Max. Continuous	5500 rpm
Idling	1400 rpm
Unusable quantity of fuel	0.5 USgal

OR

Aerobatics and intentional spins are prohibited!	
AIRSPEED IAS	
Never exceed	168 MPH
Manoeuvring	106 MPH
Max. Flap Extended	81 MPH
Stalling	44 MPH
ENGINE SPEED	
Max. Take-off (max. 5 min.)	5800 rpm
Max. Continuous	5500 rpm
Idling	1400 rpm
Unusable quantity of fuel	0.5 USgal

LOAD LIMITS							
Max.take-off weight							1320 lbs
Empty weight							700 lbs
Max.baggage weight							55 lbs
PERMITTED CREW WEIGHT							[lbs]
Fuel quantity	U.S.gal.	30,0	25,0	20,0	15,0	10,0	5,0
Baggage weight	max. 55 lbs	385	415	445	475	505	535
	1/2 28 lbs	412	442	472	502	532	562
	No baggage	440	470	500	530	560	590
Fuel reserve							2 U.S. gallons

NOTE

The values stated on the placard “LOAD LIMITS” are valid for the empty weight of the airplane with average equipment. The placard with values valid for the actual empty weight of the airplane will be placed in the cockpit.

Other placards and labels are shown in Aircraft Maintenance and Inspection Procedures.



Intentionally left blank



SECTION 3

3. EMERGENCY PROCEDURES

3.1	Introduction	3-3
3.2	Speeds for performing emergency procedures	3-3
3.3	Engine failure	3-3
3.3.1	Engine failure at take-off run.....	3-3
3.3.2	Engine failure at take-off.....	3-3
3.3.3	Engine failure in flight.....	3-4
3.4	Engine starting at flight	3-4
3.5	Engine fire	3-5
3.5.1	Fire on the ground.....	3-5
3.5.2	Fire during take-off.....	3-5
3.5.3	Fire in flight.....	3-6
3.6	Fire in the cockpit (if manual extinguisher available aboard)	3-7
3.7	Gliding flight	3-7
3.8	Emergency landing	3-8
3.8.1	Emergency landing - with non-operating engine	3-8
3.8.2	Safety landing- with engine operating.....	3-8
3.8.3	Landing with burst tire	3-9
3.8.4	Landing with damaged landing gear	3-9
3.9	Unintentional spin recovery	3-9
3.10	Other emergency procedures	3-10
3.10.1	Vibration	3-10
3.10.2	Carburettor icing	3-10
3.11	Canopy opening in flight	3-11



Intentionally left blank



3.1 Introduction

Section 3 describes operations and procedures for emergency situation solutions that could possibly occur during airplane operation.

3.2 Speeds for performing emergency procedures

Airspeed for the best gliding ratio (flaps retracted) 59 KIAS (68 mph IAS)

Precautionary landing (engine running, flaps in landing position - 50°) 55 KIAS (63 mph IAS)

Emergency landing (engine stopped, flaps in landing position - 50°) 55 KIAS (63 mph IAS)

3.3 Engine failure

3.3.1 Engine failure at take-off run

1. THROTTLE lever idle
2. Brakes as necessary
3. FUEL SELECTOR OFF
4. Ignition OFF
5. Master switch OFF

3.3.2 Engine failure at take-off

1. Gliding speed:
 - with flaps in take-off position (15°) min. 55 KIAS (63 mph IAS)
 - with flaps retracted (0°) min. 59 KIAS (68 mph IAS)
2. Altitude:
 - Land in take-off direction if below 150 ft:
 - Land in take-off direction or you can perform turn up to 90° if altitude is 150 - 400 ft:
 - You can try start engine if altitude is above 250 ft
 - You can perform turn up to 180° if altitude is above 400 ft:
3. THROTTLE lever idle



- | | |
|---------------------|-----------------|
| 4. Flaps | as needed |
| 5. FUEL SELECTOR | OFF |
| 6. Ignition | OFF |
| 7. ATC | report |
| 8. Master switch | OFF |
| 9. After touch down | brake as needed |

3.3.3 Engine failure in flight

- | | |
|------------------|--|
| 1. Gliding speed | 59 KIAS (68 mph IAS) |
| 2. Altitude | take a decision and carry out: <ul style="list-style-type: none">- Engine starting in flight - paragraph 3.4- Emergency landing - paragraph 3.8.1 |

3.4 Engine starting at flight

NOTE

It is possible to start the engine by means of the starter within the whole range of operation speeds as well as flight altitudes. The engine started up immediately after switching the ignition to START position.

If the engine is shut down, the altitude loss during engine starting can reach up to 1000 ft.

- | | |
|--|----------------------------------|
| 1. Gliding speed | 59 KIAS (68 mph IAS) |
| 2. Altitude | check |
| 3. Master switch | ON |
| 4. Electrical fuel pump (if installed) | ON |
| 5. Unnecessary electrical equipment | switch off |
| 6. FUEL SELECTOR | LEFT (or RIGHT if left is empty) |
| 7. Choke | as needed |



AIRCRAFT OPERATING INSTRUCTIONS

Doc. No. SSM2008AOIUS

- | | |
|--|----------------------|
| 5. COLD AIR knob (if installed) | push |
| After the engine stops: | |
| 6. Gliding speed | 55 KIAS (63 mph IAS) |
| 7. Ignition | OFF |
| 8. Master switch | OFF |
| 9. Land | |
| 10. Airplane | leave |
| 11. Manual extinguisher (if available) | use |

3.5.3 Fire in flight

- | | |
|---------------------------------|----------------------|
| 1. FUEL SELECTOR | OFF |
| 2. THROTTLE lever | full |
| 3. HOT AIR knob (if installed) | push |
| 4. COLD AIR knob (if installed) | push |
| 5. Gliding speed | 59 KIAS (68 mph IAS) |
| 6. Ignition | OFF |
| 7. ATC | report if possible |
| 8. Master switch | OFF |

NOTE

For extinguishing the engine fire, you can perform slip under assumption that you have sufficient altitude and time.

WARNING

AFTER EXTINGUISHING THE ENGINE FIRE START ENGINE ONLY IF IT NECESSARY TO SAFE LANDING. FUEL LEAK IN ENGINE COMPARTMENT COULD CAUSE FIRE AND FIRE COULD RESTORE AGAIN.

9. If you start engine again, switch off all switches, switch on the Master switch, and then subsequently switch on only equipment necessary to safe landing.



AIRCRAFT OPERATING INSTRUCTIONS

Doc. No. SSM2008AOIUS

- | | |
|--|--|
| 10. Emergency landing | carry out according to paragraph 3.8.1 |
| 11. Airplane | leave |
| 12. Manual extinguisher (if available) | use as needed |

3.6 Fire in the cockpit (if manual extinguisher available aboard)

- | | |
|---|---|
| 1. Fire source | identify |
| 2. Master switch in case that the source of fire is electrical equipment. | OFF |
| 3. Manual extinguisher | use |
| 4. After fire extinguishing | aerate the cockpit
open eye-ball vents |
| 5. Carry out safety landing according to | 3.8.2 |

WARNING
NEVER AGAIN SWITCH THE DEFECTIVE SYSTEM.

NOTE

If a defective electrical system circuit was detected as the fire source, then switch off appropriate circuit breaker and switch over Master switch to ON position.

3.7 Gliding flight

NOTE

Gliding flight can be used for example in case of engine failure.

Wing flaps position	Retracted (0°)	Take-off (15°)
Airspeed	59 KIAS (68 mph IAS)	55 KIAS (63 mph IAS)



3.8 Emergency landing

3.8.1 Emergency landing - with non-operating engine

1. Airspeed 59 KIAS (68 mph IAS)
2. Landing area choose,
determine wind direction
3. Safety harness tighten up
4. Flaps landing position (50°)
5. Airspeed 60 KIAS (69 mph IAS)
6. Radiostation notify situation to ATC
(if possible)
7. FUEL SELECTOR OFF
8. Ignition OFF
9. Master switch OFF before touch
down

3.8.2 Safety landing- with engine operating

1. Area for landing choose, determine wind
direction, carry out
passage flight with speed
of 59 KIAS (68 mph IAS),
flaps in take-off position

(15°)
2. Radiostation notify situation to ATC
(if possible)
3. Safety harness tighten up
4. Flaps landing position (50°)
5. Airspeed 60 KIAS (69 mph IAS)
6. Landing carry out



3.8.3 Landing with burst tire

CAUTION

WHEN LANDING AT HOLDING, KEEP THE WHEEL WITH BURST TIRE ABOVE THE GROUND AS LONG AS POSSIBLE BY MEANS OF AILERONS. IN CASE OF NOSE WHEEL BY MEANS OF ELEVATOR.

1. At running hold airplane direction by means of foot control and brakes

3.8.4 Landing with damaged landing gear

1. In case of nose landing gear damage touch down at the lowest possible speed and try to keep the airplane on main landing gear wheels as long as possible
2. In case of main landing gear damage touch down at the lowest possible speed and if possible keep direction at running

3.9 Unintentional spin recovery

NOTE

The airplane has not, when using normal techniques of pilotage, tendency to go over to spin spontaneously.

Standard procedure of recovery from spin:

- | | |
|-------------------|---|
| 1. THROTTLE lever | idle |
| 2. Control stick | ailerons - neutral position |
| 3. Pedals | kick the rudder pedal push against spin rotation direction |
| 4. Control stick | push forward and hold it there until rotation stops |
| 5. Pedals | immediately after rotation stopping, set the rudder to neutral position |
| 6. Control stick | recover the diving |



CAUTION

ALTITUDE LOSS PER ONE TURN AND RECOVERING FROM THE SPIN IS 500 UP TO 1000 FT.

3.10 Other emergency procedures

3.10.1 Vibration

If abnormal vibrations occur on the airplane then:

1. Set engine RPM to the mode in which the vibrations are the lowest
2. Land on the nearest possible airport, possibly perform safety landing according to par. 3.8.2. Safety landing.

3.10.2 Carburettor icing

Carburettor icing happens when air temperature drop in the carburettor occurs due to its acceleration in the carburettor and further cooling by evaporating fuel. Carburettor icing mostly happens during descending and approaching for landing (low engine RPM). Carburettor icing shows itself by engine power decreasing and by engine temperature increasing.

Recommended procedure for engine power regeneration is as follows:

1. CARB. PREHEATER (if installed) ON
2. THROTTLE lever set idle and cruising power again

NOTE

Ice coating in the carburettor should be removed by decrease and reincrease of engine power.

3. If the engine power is not successfully increased, then carry out landing at the nearest suitable airport or, if it is not possible, carry out precautionary landing according to par. 3.8.2 Precautionary landing.



3.11 Canopy opening in flight

WARNING

ALWAYS MAKE SURE BEFORE A TAKEOFF, THAT COCKPIT CANOPY IS FULLY CLOSED - THE RED WARNING LIGHT ON THE DASHBOARD MUST GO OFF OR, IF THE AIRPLANE IS EQUIPPED WITH DIGITAL INTEGRATED INSTRUMENTS LIKE DYNON EFIS, TL INTEGRA, FLYMAP ETC., THE APPROPRIATE LIGHT ON THE DISPLAY MUST INDICATE CLOSED CANOPY!!

All guiding pins of the tip-up canopy must be engaged into the appropriate holes of the canopy fixed frame and the lock system must be fully locked, a latch fully hooked onto the pin of fixed frame and lock handle snapped into spring bed.

If the canopy would open in flight due to improper closing, wake behind opened canopy would cause vibrations of the horizontal tail unit and consequently vibrations of the control sticks and airplane controllability would be affected.

Proceed as follows to solve such situation:

1. Grasp shaking control stick(s). This will reduce control sticks and horizontal tail unit vibrations caused by wake behind opened canopy.
2. Pull the throttle lever to reduce airspeed to approximately 120 km/h IAS, 65 KIAS, 75 mph IAS.
3. Pull opened canopy down by holding the canopy frame on either side (solo flight) or on both sides (dual flight) and keep holding the canopy pulled down. This will reduce wake acting on the horizontal tail unit and improve airplane controllability.

WARNING

**PRIORITY IS TO MAINTAIN AIRPLANE CONTROLLABILITY!
ATTEMPT TO CLOSE THE CANOPY ARE SECONDARY!**

4. Try to close the canopy, this could be possible in dual flight. If not, keep holding the canopy down by either hand.
5. Perform Safety landing according to 3.8.2.
6. It is required after landing to check conditions of the canopy and lock system. Horizontal tail unit must be inspected, as well.
7. Found faults must be fixed before next flight.



Intentionally left blank



SECTION 4

4. NORMAL PROCEDURES

4.1	Introduction	4-3
4.2	Recommended speeds for normal procedures	4-3
4.2.1	Take-off.....	4-3
4.2.2	Landing.....	4-3
4.3	Assembly and disassembly	4-3
4.4	Pre-flight check	4-4
4.5	Normal procedures and checklist	4-8
4.5.1	Before engine starting.....	4-8
4.5.2	Engine starting.....	4-8
4.5.3	Before taxiing.....	4-10
4.5.4	Taxiing.....	4-10
4.5.5	Before take-off.....	4-11
4.5.6	Take-off.....	4-12
4.5.7	Climb.....	4-12
4.5.8	Cruise.....	4-13
4.5.9	Descent.....	4-14
4.5.10	Before landing.....	4-14
4.5.11	FINAL.....	4-15
4.5.12	Balked landing.....	4-15
4.5.13	Landing.....	4-15
4.5.14	After landing.....	4-16
4.5.15	Engine shut-off.....	4-16
4.5.16	Airplane parking.....	4-17



Intentionally left blank



4.1 Introduction

Section 4 describes operations and recommended procedures for normal operation of the airplane. Normal procedures following from system installation and optional equipment, which require supplementation of these Instructions, are shown in section 9 - Supplements.

4.2 Recommended speeds for normal procedures

4.2.1 Take-off

Climbing speed up to 50 ft (flaps in take-off pos. - 15°)	57 KIAS (66 mph IAS)
Best rate-of-climb speed V_Y (flaps in take-off pos. - 15°)	57 KIAS (66 mph IAS)
Best rate-of-climb speed V_Y (flaps retracted - 0°)	65 KIAS (74 mph IAS)
Best angle-of-climb speed V_X (flaps in take-off pos. - 15°)	54 KIAS (63 mph IAS)
Best angle-of-climb speed V_X (flaps retracted - 0°)	56 KIAS (65 mph IAS)

4.2.2 Landing

Approaching speed for normal landing (flaps in landing position - 50°)	60 KIAS (69 mph IAS)
---	----------------------

4.3 Assembly and disassembly

Description of assembly and disassembly is given in the SportStar MAX Aircraft Maintenance and Inspection Procedures.



4.4 Pre-flight check

Carry out pre-flight check according to the following procedure:

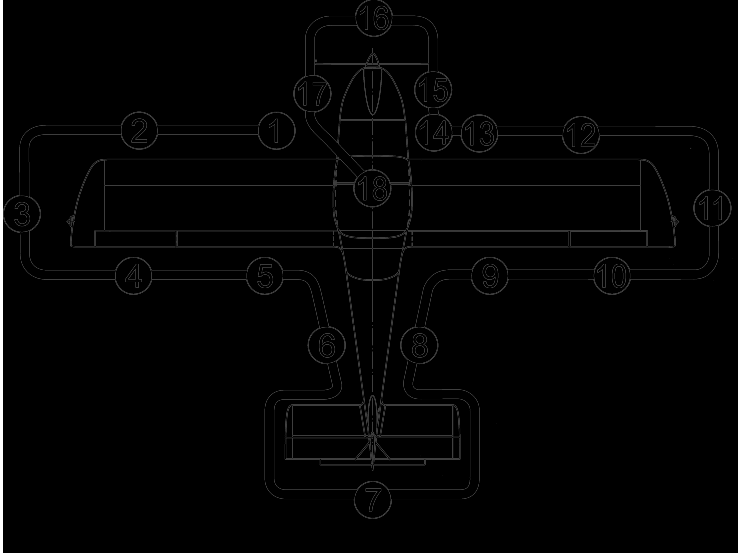

Figure 4-1 Scheme of airplane preflight check

WARNING
CHECK BEFORE PRE-FLIGHT CHECK THAT
IGNITION IS SWITCHED OFF !

NOTE

The word “condition”, used in procedures of pre-flight check, means visual check of surface, damage, deformation, scratches, attrition, corrosion, icing or other effects decreasing flight safety.



AIRCRAFT OPERATING INSTRUCTIONS

Doc. No. SSM2008AOIUS

1. Left landing gear leg - check
 - landing gear leg attachment and condition
 - landing gear wheel condition
 - tire condition and inflation
 - condition and attachment of wheel covers
 - ground cable condition (if installed)
2. Left wing - check
 - wing surface condition
 - leading edge condition
 - landing light condition - if installed
 - condition of the Pitot tube
 - draining of fuel tank (see Chapter 8, page 8-6)
 - closing of fuel tank cap
3. Left wing tip - check
 - surface condition
 - attachment check
 - fuel tank vent - cleanness
 - condition and attachment of the position lights and the anticollision beacon - if installed
4. Left aileron - check
 - surface condition
 - condition of trim tab (if installed) and its control (electr.trim)
 - attachment
 - free movement
5. Left wing flap - check
 - surface condition
 - attachment
6. Rear part of fuselage - check
 - surface condition
 - condition of antennas (top and bottom fuselage surface) - if installed



7. Tail units - check
 - tail skid condition
 - surface condition
 - condition of rudder and elevator attachment
 - freedom of rudder and elevator movement
 - condition of trim tab, condition of elevator trim tab control
8. Rear part of fuselage - check
 - surface condition
9. Right wing flap- see 5.
10. Right aileron- see 4. except the trim tab
11. Right wing tip - see 3.
12. Right wing - see 2. except the landing light
 - Alternate pitot tube (IFR airplane)
 - AOA probe (if installed)
13. Right landing gear leg - see 1.
14. Front part of the fuselage - right hand side - check
 - Tip-up canopy attachment and condition
 - condition of the nose landing gear leg
 - nose wheel condition
 - condition of the nose wheel control rods
 - external power socket (if installed)
15. Engine

Checks before the first flight of day - it is necessary to remove upper engine cowling:

 - condition of engine bed
 - condition of engine attachment
 - condition of exhaust system
 - condition of engine cowlings
 - visual check on fuel and electrical system condition



AIRCRAFT OPERATING INSTRUCTIONS

Doc. No. SSM2008AOIUS

- check on cooling liquid volume in the expansion tank on the engine body
(replenish as required up to max. 2/3 of the expansion tank volume)

Checks before every flight:

- cleanness of air intakes
 - check on oil level (between marks - flattenings on the dip stick)
 - check on cooling liquid level in the overflow bottle (volume should be approx. 0.42 pints (0.2 litre))
 - proper closing of the upper cowling
16. Propeller - check
- attachment
 - condition of blades, hub and spinner
17. Front part of fuselage - left hand side - check
- tip-up canopy attachment and condition
18. Cockpit - check

NOTE

Canopy is unlocked if a latch next to lock is visible under the glass, otherwise it is locked. Unlock it first with key.

- Master switch switched on
- Check canopy OPEN/CLOSE indication light (or a message on the EFIS display) function
- all switches OFF
- instrument equipment check on condition
- check of safety belts condition and attachment
- check on presence of loose object in the cockpit
- check on adjusting and securing the rudder pedals (see section 7.3.3) - if installed adjustable rudder pedals

WARNING

RIGHT AND LEFT PEDAL OF RUDDER CONTROL MUST BE SET TO THE SAME POSITIONS AND WELL SECURED!

AOI and other required documents check on completeness and validity



4.5 Normal procedures and checklist

4.5.1 Before engine starting

1. Pre-flight check and check on weight and centre of gravity position done
2. External power source (if socket is installed) connect as necessary
3. Safety harnesses check, fasten
4. Control stick free
5. Rudder pedals free
6. Wing flaps function check
7. Trim tab function check
8. PARKING BRAKE handle (if installed) release brakes
9. Brakes function check
10. AVIONICS SWITCH check OFF
11. Ignition check OFF
12. Canopy close

4.5.2 Engine starting

1. Master switch ON
2. Fuel gauge indicators check of fuel qty.
3. FUEL SELECTOR LEFT
Pull the safety button on the fuel selector, turn the handle to the left and then release safety button. Now the handle can be freely moved between left and right position. Safety button prevents unintentionally switch the selector to OFF position.
4. Electric fuel pump (if installed) ON
5. THROTTLE lever idle
6. Choke as necessary (open by pulling up and lock by turning)
7. Space in the propeller area free



AIRCRAFT OPERATING INSTRUCTIONS

Doc. No. SSM2008AOIUS

- | | |
|--------------------------|---|
| 8. BEACON (if installed) | ON
(if necessary) |
| 9. Brakes | apply |
| 10. Ignition | START (see CAUTION)
after starting up BOTH |

CAUTION

ACTIVATE STARTER FOR 10 SEC. AS A MAXIMUM, THEN LET IT COOL DOWN FOR 2 MINUTES.

AFTER STARTING UP ENGINE, DO NOT CARRY OUT SUDDEN RPM CHANGES, AFTER POWER DECREASE WAIT FOR ABOUT 3 S IN ORDER TO REACH CONSTANT RPM BEFORE REACCELERATION.

- | | |
|--------------------------------------|-------------------------|
| 11. THROTTLE lever | as necessary (see NOTE) |
| 12. Oil pressure | up to 10s min. pressure |
| 13. GEN, AUX GEN (if inst.) switches | ON |

NOTE

After starting up engine, adjust throttle for smooth engine running at about 2500 RPM. Check oil pressure. Pressure must increase within 10 s. Increase engine RPM until oil pressure is stabilised over 2 bar (29 PSI).

- | | |
|------------------------|--------------|
| 14. Engine instruments | check |
| 15. Choke | as necessary |
| 16. Engine warming up | see NOTE |

NOTE

Begin warming up with engine running at 2000 RPM. for about 2 minutes, continue at 2500 RPM. Warming time depends on outside air temperature until oil temperature reaches 122 °F.

- | | |
|-------------------|--|
| 17. FUEL SELECTOR | RIGHT
Verify proper engine feeding from the right tank for approx.
1 minute. |
| 18. FUEL SELECTOR | LEFT |



NOTE

Start engine with the fuel selector set to to **LEFT**. If you would start the engine with the fuel selector set to **RIGHT** and the left tank is full, than fuel bleed from the left tank vent may occur (and pollute environment) because a fuel return hose is led only into the left tank and returning fuel will overfill the left tank.

- | | |
|---|--|
| 19. External power source
(if socket is installed) | if used,
give instruction to
disconnect it |
| 20. AVIONICS SWITCH | ON |
| 21. Radiostation/avionics | ON |
| 22. Other electrical equipment | ON as necessary |

4.5.3 Before taxiing

- | | |
|----------------------------------|--------------|
| 1. Transponder (if installed) | SBY |
| 2. Outside lights (if installed) | as necessary |

4.5.4 Taxiing

- | | |
|---|------------------------|
| 1. THROTTLE lever | as necessary |
| 2. Brakes | check by
depressing |
| 3. Rudder pedals | function check |
| 4. Direction of taxiing control by rudder pedals (these are mechanically connected with nose wheel control), possibly by slacking up left and right wheel of the main landing gear. | |



AIRCRAFT OPERATING INSTRUCTIONS

Doc. No. SSM2008AOIUS

4.5.5 Before take-off

1. Brakes brake
2. Ignition check carry out,
see NOTE

NOTE

Carry out ignition check in the following way :
Set engine speed to 4000 RPM. Switch ignition gradually to L, BOTH, R position and return to BOTH..

RPM drop with one ignition circuit switched off must not exceed 300 RPM. Maximum RPM difference at using one of the L or R circuits is 120 RPM.

3. Engine instruments check
4. Control stick free
5. Wing flaps Take-off pos. (15°)
6. Elevator trim NEUTRAL
7. Aileron trim (if installed) NEUTRAL
8. Fuel gauge indicator check on fuel quantity
8. FUEL SELECTOR check LEFT
10. CARB.R PREHEATER (if installed) check function
then OFF

NOTE

If CARBURETTOR PREHEATER is switched ON, then engine RPM drop reaches approximately 50 RPM

11. Engine instruments check
12. Flight instruments check
13. Radiostation / avionics check, set
14. Ignition check BOTH
15. Choke close (in inserted
position)



- | | |
|--------------------------------|------------|
| 16. Master switch | check ON |
| 17. Safety harnesses | tighten up |
| 18. Canopy | closed |
| 19. Transponder (if installed) | ON or ALT |

4.5.6 Take-off

1. THROTTLE lever max. take-off power
2. During take-off run smoothly lighten up the nose landing gear until airplane take-off occurs.
3. Airspeed 57 KIAS (66 mph IAS)
4. Brakes brake to stop main wheel rotation
5. After reaching 150 ft , set flaps to retracted pos. (0°)
6. Trim as necessary

WARNING
TAKE-OFF IS PROHIBITED:
*** IF ENGINE RUNNING IS IRREGULAR**
*** IF CHOKE IS OPEN**
*** IF VALUES OF ENGINE INSTRUMENTS ARE**
NOT WITHIN THE REQUIRED RANGE

4.5.7 Climb

1. THROTTLE lever max. continuous power
2. Airspeed $V_Y = 65$ KIAS (75 mph IAS) for the best rate of climb or $V_X = 56$ KIAS (64 mph IAS) for the best angle of climb
3. Engine instruments check
4. Trim as necessary
5. Electric fuel pump (if installed) OFF



AIRCRAFT OPERATING INSTRUCTIONS

Doc. No. SSM2008AOIUS

4.5.8 Cruise

- | | |
|-----------------------|---------------|
| 1. THROTTLE lever | as necessary |
| 2. Airspeed | max. 5500 RPM |
| 3. Engine instruments | check |
| 4. Fuel quantity | check |

CAUTION

FUEL GAUGES DISPLAY TRUE FUEL QUANTITY ONLY ON GROUND AND IN A LEVEL FLIGHT. TO READ TRUE FUEL QUANTITY AFTER TRANSITION FROM CLIMB/DESCENT WAIT APPROX. 2 MINUTES TO FUEL TO LEVEL.

NOTE

It is recommended to alternately switch the tanks during cruise to equally consume fuel from both tanks and minimize airplane tendency to bank with unbalanced tanks.

Do not fly with the fuel selector set to RIGHT if the left tank is full to avoid fuel bleed from left tank vent.

When the left tank fuel gauge indicates approx. 1/8 of fuel quantity (needle in the middle between 1/4 and 0) then switch to the right tank to consume remaining fuel and then switch back the left tank to complete the flight at left tank. If the engine conks out due to fuel consumption from either tank, then immediately switch the fuel selector to other tank and engine run will be recovered within 7 seconds.

5. CARB.PREHEATER (if installed) as necessary



4.5.9 Descent

- | | |
|----------------------------------|--------------|
| 1. THROTTLE lever | as necessary |
| 2. Airspeed | as necessary |
| 3. Trim | as necessary |
| 4. Engine instruments | check |
| 5. CARB.PREHEATER (if installed) | as necessary |

CAUTION

AT LONG APPROACHING AND DESCENDING FROM HIGH ALTITUDE IT IS NOT SUITABLE TO REDUCE THROTTLE TO MINIMUM FOR THE REASON OF POSSIBLE ENGINE UNDERCOOLING AND SUBSEQUENT LOSS OF POWER. PERFORM DESCENDING AT INCREASED IDLE AND CHECK OBSERVANCE OF THE ALLOWED VALUES ON ENGINE INSTRUMENTS.

4.5.10 Before landing

- | | |
|------------------|-------|
| 1. Fuel quantity | check |
|------------------|-------|

CAUTION

FUEL GAUGES DISPLAY TRUE FUEL QUANTITY ONLY ON GROUND AND IN A LEVEL FLIGHT. TO READ TRUE FUEL QUANTITY AFTER TRANSITION FROM CLIMB/DESCENT WAIT APPROX. 2 MINUTES TO FUEL TO LEVEL.

- | | |
|----------------------------------|----------------------------|
| 2. FUEL SELECTOR | LEFT |
| 3. Engine instruments | check |
| 4. Brakes | check by depressing pedals |
| 5. Safety harnesses | tighten up |
| 6. Free area of landing | check |
| 7. CARB.PREHEATER (if installed) | ON |



AIRCRAFT OPERATING INSTRUCTIONS

Doc. No. SSM2008AOIUS

- | | |
|----------------------------------|----------------------|
| 8. Approaching speed | 60 KIAS (69 mph IAS) |
| 9. Flaps | Take-off pos. (15°) |
| 10. Trim | as necessary |
| 11. Parking brake (if installed) | check for lever down |

CAUTION

**PARKING BRAKE MUST BE RELEASED
(LEVER DOWN) TO PREVENT LANDING WITH
BRAKED WHEELS.**

- | | |
|---------------------------------------|----|
| 12. Electric fuel pump (if installed) | ON |
|---------------------------------------|----|

4.5.11 FINAL

- | | |
|----------------------------------|---------------------------|
| 1. Flaps | landing pos. (30° or 50°) |
| 2. Maintain airspeed | 60 KIAS (69 mph IAS) |
| 3. Trim | as necessary |
| 4. CARB.PREHEATER (if installed) | OFF |

4.5.12 Balked landing

- | | |
|----------------------|-----------------------|
| 1. THROTTLE lever | max. take-off power |
| 2. Flaps | take-off pos. (15°) |
| 3. Airspeed | 56 KIAS (65 mph IAS) |
| 4. Flaps in 150 ft | retracted pos. (0°) |
| 5. Trim | as necessary |
| 6. THROTTLE lever | max. continuous power |
| 7. Instruments | check |
| 8. Climb at airspeed | 65 KIAS (74 mph IAS) |

4.5.13 Landing

- | | |
|---|--------------|
| 1. THROTTLE lever | idle |
| 2. Touch-down on main landing gear wheels | carry out |
| 3. Brakes after nose landing gear
wheel touch-down | as necessary |



4.5.14 After landing

- | | |
|--------------------------------------|---------------------|
| 1. Flaps | retracted pos. (0°) |
| 2. Trim | NEUTRAL |
| 3. Outside lights (if installed) | OFF |
| 4. Transponder (if installed) | OFF |
| 5. Electric fuel pump (if installed) | OFF |

4.5.15 Engine shut-off

- | | |
|-------------------------------|-------|
| 1. THROTTLE lever | idle |
| 2. Engine instruments | check |
| 3. AVIONICS SWITCH | OFF |
| 4. Radiostation / avionics | OFF |
| 5. Other electrical equipment | OFF |
| 6. Ignition | OFF |
| 7. BEACON (if installed) | OFF |
| 8. Master switch | OFF |



AIRCRAFT OPERATING INSTRUCTIONS

Doc. No. SSM2008AOIUS

4.5.16 Airplane parking

1. Ignition check OFF
2. Master switch check OFF
3. FUEL SELECTOR OFF
Pull the safety button on the fuel selector, turn the handle to the OFF position and then release safety button. Now the handle is blocked in the OFF position. Safety button prevents unintentionally switch the selector from the OFF position.
4. PARKING BRAKE handle (if installed) brake as necessary
5. Canopy close,
lock as necessary

NOTE

It is recommended to use parking brake (if installed) for short-time parking only, between flights during a flight day. After ending the flight day or at low temperatures of ambient air, do not use parking brake, but use the wheel chocks instead.

If after releasing the parking brake wheels (or one of them) stay blocked, depress and release the brake pedals. This procedure should result to unblock wheels. If the wheel or wheels fail to unblock by the process (even after repeated depressing) it is necessary to allow vent valve (in the appropriate wheel) and reduce the pressure in the brake circuit.



Intentionally left blank



SECTION 5

5. PERFORMANCE

5.1	Introduction	5-3
5.2	Approved data	5-4
5.2.1	Airspeed indicator system calibration	5-4
5.2.2	Stall speeds.....	5-6
5.2.3	Take-off distance	5-7
5.2.4	Landing distance	5-7
5.2.5	Climb performance.....	5-8
5.3	Additional information	5-10
5.3.1	Cruise	5-10
5.3.2	Horizontal speeds	5-11
5.3.3	Endurance.....	5-12
5.3.4	Balked landing climb	5-13
5.3.5	Effect on flight performance and characteristics.....	5-14
5.3.6	Demonstrated crosswind performance	5-14
5.3.7	Ceiling	5-15
5.3.8	Noise data	5-15



Intentionally left blank



AIRCRAFT OPERATING INSTRUCTIONS

Doc. No. SSM2008AOIUS

5.1 Introduction

Section 5 provides data for airspeed calibration, stall speeds, take-off performance and additional information, provided by the airplane manufacturer.

The stated performance data has been computed from actual flight tests with the airplane and engine in good condition and using average piloting techniques.

CAUTION

THE PERFORMANCE STATED IN THIS SECTION IS VALID FOR STANDARD POWERPLANT - ROTAX 912 ULS (100 HP) TOGETHER WITH WOODCOMP KLASSIC 170/3/R PROPELLER INSTALLED IN THE AIRPLANE.

FOR ACTUAL PERFORMANCE SEE SECTION 9 - SUPPLEMENTS.



5.2 Approved data

5.2.1 Airspeed indicator system calibration

NOTE

Assumed zero instrument error. Valid for airplane take-off weight 1320 lbs (600 kg) and with vortex generators along the whole span of the wing.

		RETRACTED 0°	TAKEOFF 15°	LANDING I 30°	LANDING II 50°
	KIAS	KCAS	KCAS	KCAS	KCAS
VS0	37		43	42	42
VS1	38	45	44	43	42
	39	46	44	44	43
	40	47	45	45	44
	41	48	46	46	45
	42	48	47	47	46
	43	49	48	48	47
	44	50	49	48	48
	45	51	50	49	48
	50	55	54	53	53
	55	59	58	58	57
	60	63	62	62	62
	65	67	67	66	66
	VFE	70	71	71	70
75		75			
80		80			
85		84			
VA	90	89			
	95	93			
	100	98			
	105	103			
VNO	110	107			
	115	112			
	120	117			
	125	122			
	130	127			
VNE	135	132			
	140	138			
	146	144			



AIRCRAFT OPERATING INSTRUCTIONS

Doc. No. SSM2008AOIUS

	RETRACTED		TAKEOFF 15°	LANDING I 30°	LANDING II 50°
	IAS (mph)	CAS (mph)	CAS (mph)	CAS (mph)	CAS (mph)
VS0	43		49	49	48
VS1	44	52	50	50	49
	45	53	51	51	50
	50	57	56	55	54
	55	61	60	59	59
	60	65	64	64	63
	65	69	68	68	67
	70	73	73	72	72
	75	77	77	76	76
	80	81	81	80	80
VFE	81	82	82	81	81
	85	86			
	90	90			
	95	94			
	100	99			
	105	103			
VA	106	104			
	110	108			
	115	113			
	120	117			
	125	122			
	130	127			
VNO	132	129			
	135	132			
	140	137			
	145	142			
	150	147			
	155	152			
	160	157			
	165	162			
VNE	168	166			



5.2.2 Stall speeds

Conditions:

- wing level stall - engine at idle power
- turning flight stall - engine at 75% max. continuous power
- airplane weight: 1320 lbs (600 kg)
- Vortex generators along the whole span of the wing

NOTE

The stated stall speeds are valid for all flight altitudes. Altitude losses shown in the table present max. values determined on the basis of flight tests using average piloting technique.

1320 lbs 600 kg	Flaps position	Stall speed		Altitude loss ft
		KIAS	KCAS	
Wing level flight	Retracted (0°)	38	45	200
	Take-off (15°)	37	43	
	Landing (50°)	37	42	
Turn flight (coordinated turn 30° bank)	Retracted (0°)	44	50	200
	Take-off (15°)	43	48	
	Landing (50°)	43	47	

1320 lbs 600 kg	Flaps position	Stall speed		Altitude loss ft
		IAS [mph]	CAS [mph]	
Wing level flight	Retracted (0°)	44	52	200
	Take-off (15°)	43	49	
	Landing (50°)	43	48	
Turn flight (coordinated turn 30° bank)	Retracted (0°)	50	57	200
	Take-off (15°)	49	55	
	Landing (50°)	49	54	



AIRCRAFT OPERATING INSTRUCTIONS

Doc. No. SSM2008AOIUS

5.2.3 Take-off distance

- Conditions:**
- engine: max. take-off power
 - flaps: Take-off (15°)
 - carburetter preheating: OFF
 - airplane weight: 1268 lbs
 - altitude: 0 ft ISA
 - ambient air temperature: ISA

	Take-off run	Take-off distance to height of 50 ft (15 ft)
Dray concrete	620 ft	1440 ft
Grass	720 ft	1540 ft

- Corrections:**
- Influence of wind: Add 4% on every 1 kt (1.15 mph) of tail wind
 - RWY inclination: Add 8% of the take-off run distance on 1% of runway inclination up the slope

5.2.4 Landing distance

- Conditions:**
- engine: idle
 - flaps: Landing 50°
 - carburetter preheating: OFF
 - airplane weight: 1268 lbs
 - altitude: 0 ft ISA
 - ambient air temperature: ISA

	Landing distance from height of 50 ft (15 ft)	Braked landing run
Dray concrete	1310 ft	590 ft
Grass	1250 ft	520 ft

- Corrections:**
- Influence of wind: Add 4.5 % on every 1 kt (1.15 mph) of tail wind
 - RWY inclination: Add 8% of the landing run distance on 1% of runway inclination down the slope



5.2.5 Climb performance

Conditions:

- engine: maximum take-off power
- flaps: retracted (0°)
- carburetter preheating: OFF
- airplane weight: 1320 lbs
- vortex generators along the whole span of the wing
- ambient air temperature: ISA

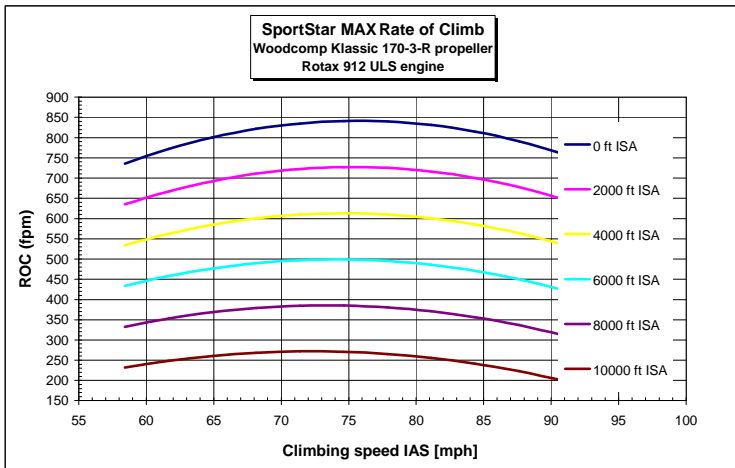
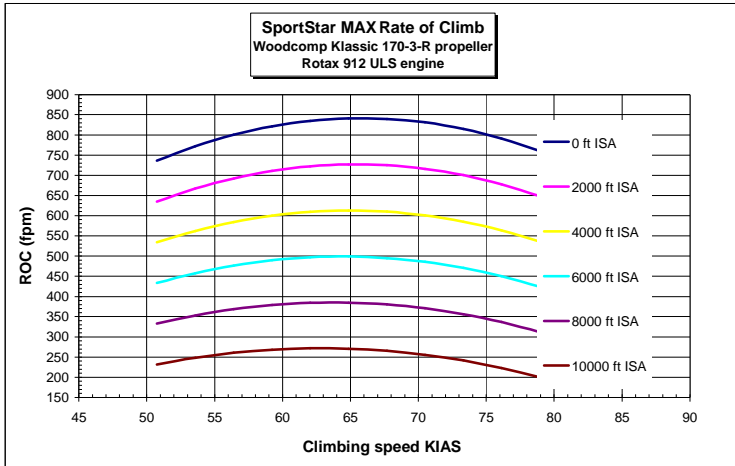



AIRCRAFT OPERATING INSTRUCTIONS

Doc. No. SSM2008AOIUS

Best rate of climb for various altitudes is mentioned in the following table:

Altitude	Best rate of climb speed		Max. ROC
Hp [ft ISA]	KIAS	IAS [mph]	[fpm]
0 ft ISA	66	76	840
2000 ft ISA	65	75	730
4000 ft ISA	65	75	610
6000 ft ISA	64	74	500
8000 ft ISA	64	74	390
10000 ft ISA	63	72	270



AIRCRAFT OPERATING INSTRUCTIONS

Doc. No. SSM2008AOIUS

5.3 Additional information

5.3.1 Cruise

Conditions:

- flaps: retracted (0°)
- carburetter preheating: OFF
- airplane weight: 1320 lbs (600 kg)
- vortex generators along the whole span of the wing
- ambient air temperature: ISA

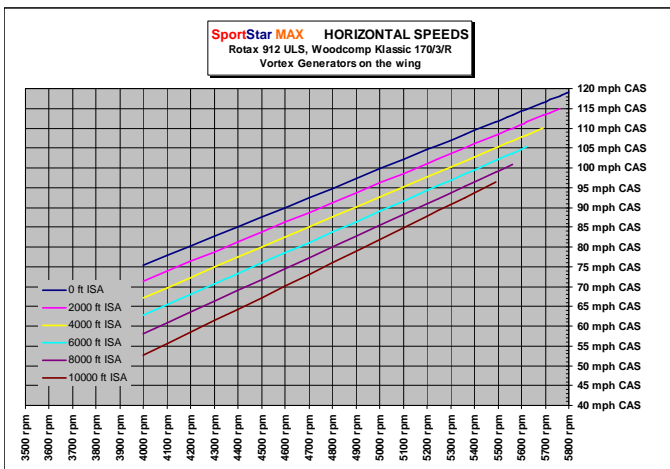
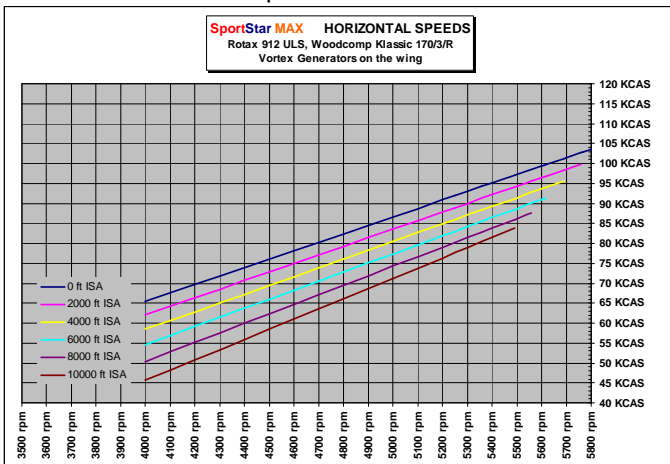



AIRCRAFT OPERATING INSTRUCTIONS

Doc. No. SSM2008AOIUS

5.3.2 Horizontal speeds

In the following table states Indicated airspeeds (IAS), corresponding calibrated air speeds (CAS) and true air speeds (TAS) versus altitude, all for various engine speeds.

		55% MTV	65% MTV	75% MTV	MCP Maximum Continuous Power	MTP Maximum Takeoff Power (5 min.)
		4300 rpm	4800 rpm	5000 rpm	5500 rpm	5800 rpm
0 ft ISA	KIAS	71	83	88	99	106
	KCAS	72	82	87	97	103
	KTAS	72	82	87	97	104

2000 ft ISA	KIAS	67	80	84	96
	KCAS	69	79	84	94
	KTAS	71	82	86	97

4000 ft ISA	KIAS	63	76	81	93
	KCAS	65	76	80	91
	KTAS	69	81	85	97

6000 ft ISA	KIAS	58	72	77	90
	KCAS	61	73	77	89
	KTAS	67	80	85	97

8000 ft ISA	KIAS	54	68	74	87
	KCAS	58	69	74	86
	KTAS	65	78	84	97

10000 ft ISA	KIAS	48	64	70	
	KCAS	53	66	71	
	KTAS	62	77	83	

		55% MTV	65% MTV	75% MTV	MCP Maximum Continuous Power	MTP Maximum Takeoff Power (5 min.)
		4300 rpm	4800 rpm	5000 rpm	5500 rpm	5800 rpm
0 ft ISA	IAS [mph]	82	96	101	114	122
	CAS [mph]	83	95	100	112	119
	TAS [mph]	83	95	100	112	119

2000 ft ISA	IAS [mph]	77	91	97	111
	CAS [mph]	79	91	96	109
	TAS [mph]	81	94	99	112

4000 ft ISA	IAS [mph]	72	87	93	107
	CAS [mph]	75	88	93	105
	TAS [mph]	79	93	98	112

6000 ft ISA	IAS [mph]	67	83	89	104
	CAS [mph]	71	84	89	102
	TAS [mph]	77	92	97	112

8000 ft ISA	IAS [mph]	62	78	85	100
	CAS [mph]	66	80	85	99
	TAS [mph]	75	90	96	112

10000 ft ISA	IAS [mph]	56	74	81	
	CAS [mph]	61	76	82	
	TAS [mph]	71	89	95	



AIRCRAFT OPERATING INSTRUCTIONS

Doc. No. SSM2008AOIUS

5.3.3 Endurance

Conditions:

- flaps: retracted (0°)
- carburetter preheating: OFF
- airplane takeoff weight: 1320 lbs (600 kg)
- airplane empty weight: 740 lbs (335 kg)
- vortex generators along the whole span of the wing
- ambient air temperature: ISA

LOAD LIMITS	
Max.take-off weight	1320 lb
Empty weight	740 lb
Max.baggage weight	55 lb

PERMITTED CREW WEIGHT

		30 USGAL	25 USGAL	20 USGAL	15 USGAL	10 USGAL	5 USGAL
Baggage max.	55 lb	345 lb	375 lb	405 lb	435 lb	465 lb	495 lb
Baggage 1/2	28 lb	372 lb	402 lb	432 lb	462 lb	492 lb	522 lb
No baggage	0 lb	400 lb	430 lb	460 lb	490 lb	520 lb	550 lb

ENDURANCE AND RANGE Altitude 2000 ft ISA		55% MCP	65% MCP	75% MCP	MCP Max.Continuous Power
Engine speed	[rpm]	4300	4800	5000	5500
Fuel consumption	[USgal/h]	3,7	4,9	5,4	6,6
IAS	[knots]	67	80	84	96
	[mph]	77	91	97	111
CAS	[knots]	69	79	84	94
	[mph]	79	91	96	109
TAS	[knots]	71	82	86	97
	[mph]	81	94	99	112

Endurance at	30 USGAL	[h:m]	8:03	6:05	5:31	4:31
Range at		[NM]	570	500	480	440
		[miles]	660	580	550	510

Endurance at	25 USGAL	[h:m]	6:42	5:04	4:36	3:46
Range at		[NM]	470	410	400	370
		[miles]	540	470	460	430

Endurance at	20 USGAL	[h:m]	5:22	4:03	3:41	3:00
Range at		[NM]	380	330	320	290
		[miles]	440	380	370	330

Endurance at	15 USGAL	[h:m]	4:01	3:02	2:45	2:15
Range at		[NM]	280	250	240	220
		[miles]	320	290	280	250

Endurance at	10 USGAL	[h:m]	2:41	2:01	1:50	1:30
Range at		[NM]	190	170	160	150
		[miles]	220	200	180	170

Endurance at	5 USGAL	[h:m]	1:20	1:00	0:55	0:45
Range at		[NM]	90	80	80	70
		[miles]	100	90	90	80



AIRCRAFT OPERATING INSTRUCTIONS

Doc. No. SSM2008AOIUS

5.3.4 Balked landing climb

Conditions:

- engine: maximum take-off power
- carburettor preheating: OFF
- flaps: landing position (50°)
- airplane weight: 1320 lbs (600 kg)
- vortex generators along the whole span of the wing
- ambient air temperature: ISA

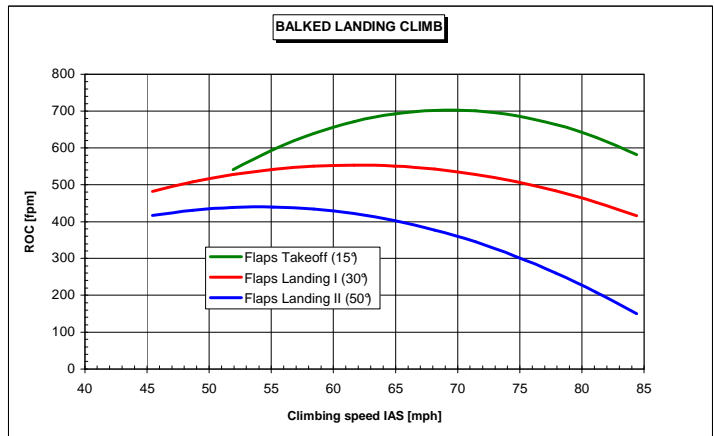
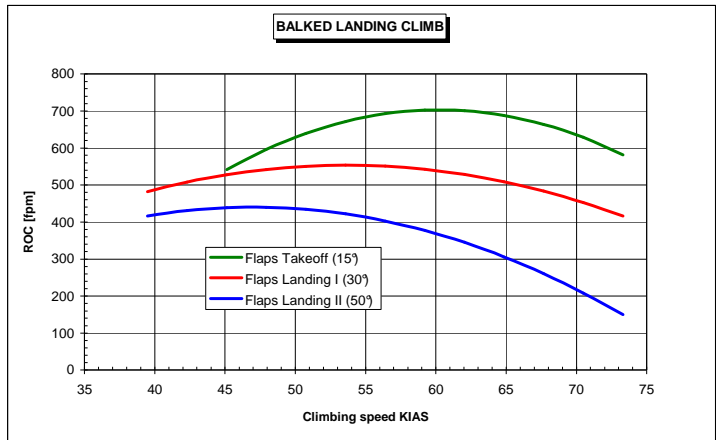



5.3.5 Effect on flight performance and characteristics

Flight performances and characteristics are not considerably affected by rain or insect stuck on the airplane surface.

5.3.6 Demonstrated crosswind performance

Maximum demonstrated speed of wind at airplane operation 24 kts (28 mph)

Maximum demonstrated speed of cross wind for take-off and landing 16 kts (18.4 mph)

Maximum demonstrated speed of tail wind 6 kts (7 mph)

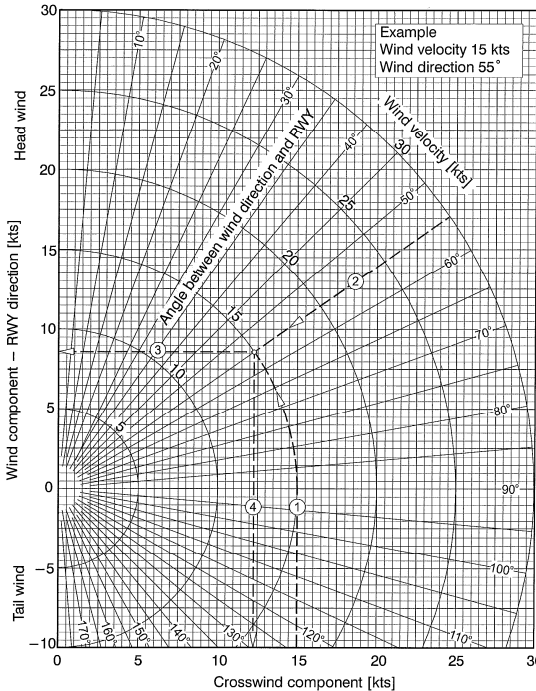

Figure 5-1 Influence of wind on take-off and landing



AIRCRAFT OPERATING INSTRUCTIONS

Doc. No. SSM2008AOIUS

5.3.7 Ceiling

Service ceiling (ROC 100 fpm)

13 000 ft

5.3.8 Noise data

Not measured.



Intentionally left blank



SECTION 6

6. WEIGHT AND BALANCE

6.1	Introduction.....	6-3
6.2	Weight and Balance Record.....	6-4
6.3	Permitted Payload Range.....	6-5
6.4	Operational Weight and Balance Computation.....	6-5
6.4.1	Computational Procedure.....	6-6
6.5	Airplane Loading Schedule Chart.....	6-8
6.6	Table of Static Moments.....	6-9
6.7	Airplane Loading Graph.....	6-10
6.8	CG Moment Envelope.....	6-11
6.9	Operational Weight and CG Envelope.....	6-12
6.10	Equipment List.....	6-13



Intentionally left blank



6.1 Introduction

This Section includes Weight and Balance Record of empty airplane, Permitted Payload Range within which the airplane may be safely operated, and a method to determine whether the operational weight and CG location will be within the permitted limits range.

Procedure for weighing the airplane and the calculation method for establishing the permitted payload range are contained in the Aircraft Maintenance and Inspection Procedures for the SportStar MAX Light Sport Aircraft.



AIRCRAFT OPERATING INSTRUCTIONS

Doc. No. SSM2008AOIUS

6.3 Permitted Payload Range

MAXIMUM WEIGHT OF CREW [lb]		Airplane S/N: 2016 1731						MTOW [lb]:1320				
Date	Empty weight [lb]	C.G. [% MAC]	FUELLING						Approved			
			Fuel volume	1	0.8	0.6	0.4	0.3	0.2	Date	Signature	
			Fuel volume [US gals]	30	25	20	15	10	5			
			Fuel weight [lb]	180	150	120	90	60	30			
			BAGGAGE [lb]									
	765	19.81	55	320	350	380	410	440	470			
			28	347	377	407	437	467	497			
			0	375	405	435	465	495	525			
			55									
			28									
			0									
			55									
			28									
			0									
			55									
			28									
			0									



6.4 Operational Weight and Balance Computation

An important part of preflight planning is to determine that the aircraft is loaded so its weight and CG location are within the allowable limits.

This is possible by using hereafter explained Loading graph method, using weights, arms, and moment indexes.

6.4.1 Computational Procedure

1. Record into the **Airplane Loading Schedule Chart** current empty weight and static moment of the airplane, which you read from the table 6.2 Weight and Balance Record.
2. Record the weight of crew, fuel, and baggage into the **Airplane Loading Schedule Chart**.
3. See the **Table of Static Moments** or **Airplane Loading Graph** to read static moments for given weights of crew, fuel, and baggage
4. Record found moments into the **Airplane Loading Schedule Chart**
5. Determine Take-off weight of the airplane – add together the airplane empty weight, crew, fuel, and baggage and record the result into the **Loading Schedule Chart**.
6. Check, whether the calculated Take-off weight does not exceed Airplane Maximum Take-off Weight 1320 lb.
If yes, then it is necessary to reduce weight of some of the useful load items (fuel, baggage).

WARNING
EXCEEDING MTOW MAY LEAD TO
DETERIORATION OF SAFETY OF FLIGHT!

7. Determine Total Static Moment of loaded airplane – add together the static moment of empty airplane, crew, fuel, and baggage and record the result into the **Loading Schedule Chart**.
8. Plot Takeoff Weight and Total Static Moment into the **SportStar MAX CG Moment Envelope**.
9. Check, whether the intersection of Take-off weight horizontal line and Total Static Moment vertical line is inside the envelope.
If **YES**, then the flight may be safely performed as regards weight and balance.
If **NOT**, then it is necessary to change weight of some of the



AIRCRAFT OPERATING INSTRUCTIONS

Doc. No. SSM2008AOIUS

useful load items (crew, fuel, baggage) so that after a repeated computation the intersection of Take-off Weight and Total Static Moment will be inside the CG Moment envelope.

WARNING

**SAFETY OF FLIGHT PERFORMED WITH THE
AIRPLANE LOADED OUTSIDE PERMITTED
LIMITS OF WEIGHT AND STATIC MOMENTS
MAY BE DETERIORATED!**



6.5 Airplane Loading Schedule Chart

Type / Model	SportStar MAX	Serial No.:		Registration:	
--------------	---------------	-------------	--	---------------	--

Loading Schedule Chart							
Your Aircraft			Sample Aircraft			Your Aircraft	
No	Item	Arm * (in)	Arm (in)	Weight (lb)	Moment/100 (lb-in)	Weight (lb)	Moment/100 (lb-in)
1.	Empty Airplane		10,39 in	740,75 lb	77,1 lb-in		
2.	Crew	21,45 in		399,04 lb	85,6 lb-in		
3.	Baggage (Max. 55 lb)	42,65 in		11,02 lb	4,7 lb-in		
4.	Fuel (Max. 32 USGAL)	26,75 in		60,41 lb	16,2 lb-in		
5.	Take off weight = Sum of weights 1-4 (MTOW 1320 lb) Total moment = Sum of moments 1-4			1211 lb	184 lb-in		

*) – for your empty airplane arm see Weight and Balance Record delivered with your airplane



AIRCRAFT OPERATING INSTRUCTIONS

Doc. No. SSM2008AOIUS

6.6 Table of Static Moments

CREW		BAGGAGE		FUEL		
Weight (lb)	Moment/100 (lb-in)	Weight (lb)	Moment/100 (lb-in)	Quantity (USGAL)	Weight (lb)	Moment/100 (lb-in)
0	0,0	0	0,0	0,0	0,0	0,0
100	21,5	2	0,9	1,0	6,0	1,6
120	25,7	4	1,7	2,0	12,0	3,2
140	30,0	6	2,6	3,0	18,0	4,8
160	34,3	8	3,4	4,0	24,0	6,4
180	38,6	10	4,3	5,0	30,0	8,0
200	42,9	12	5,1	6,0	36,1	9,6
220	47,2	14	6,0	7,0	42,1	11,3
240	51,5	16	6,8	8,0	48,1	12,9
260	55,8	18	7,7	9,0	54,1	14,5
280	60,1	20	8,5	10,0	60,1	16,1
300	64,4	22	9,4	11,0	66,1	17,7
320	68,6	24	10,2	12,0	72,1	19,3
340	72,9	26	11,1	13,0	78,1	20,9
360	77,2	28	11,9	14,0	84,1	22,5
380	81,5	30	12,8	15,0	90,1	24,1
400	85,8	32	13,6	16,0	96,1	25,7
420	90,1	34	14,5	17,0	102,1	27,3
440	94,4	36	15,4	18,0	108,2	28,9
460	98,7	38	16,2	19,0	114,2	30,5
480	103,0	40	17,1	20,0	120,2	32,2
500	107,3	42	17,9	21,0	126,2	33,8
520	111,5	44	18,8	22,0	132,2	35,4
540	115,8	46	19,6	23,0	138,2	37,0
560	120,1	48	20,5	24,0	144,2	38,6
		50	21,3	25,0	150,2	40,2
		52	22,2	26,0	156,2	41,8
		54	23,0	27,0	162,2	43,4
		55	23,5	28,0	168,2	45,0
				29,0	174,3	46,6
				30,0	180,3	48,2
				31,0	186,3	49,8
				32,0	192,3	51,4



6.7 Airplane Loading Graph

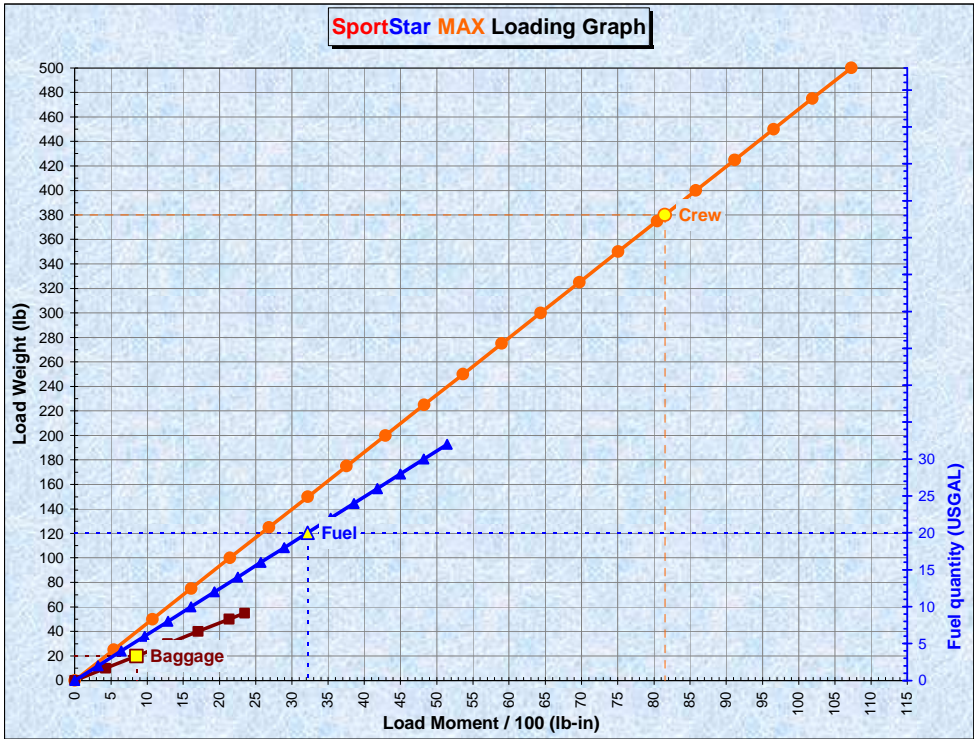



AIRCRAFT OPERATING INSTRUCTIONS

Doc. No. SSM2008AOIUS

6.8 CG Moment Envelope

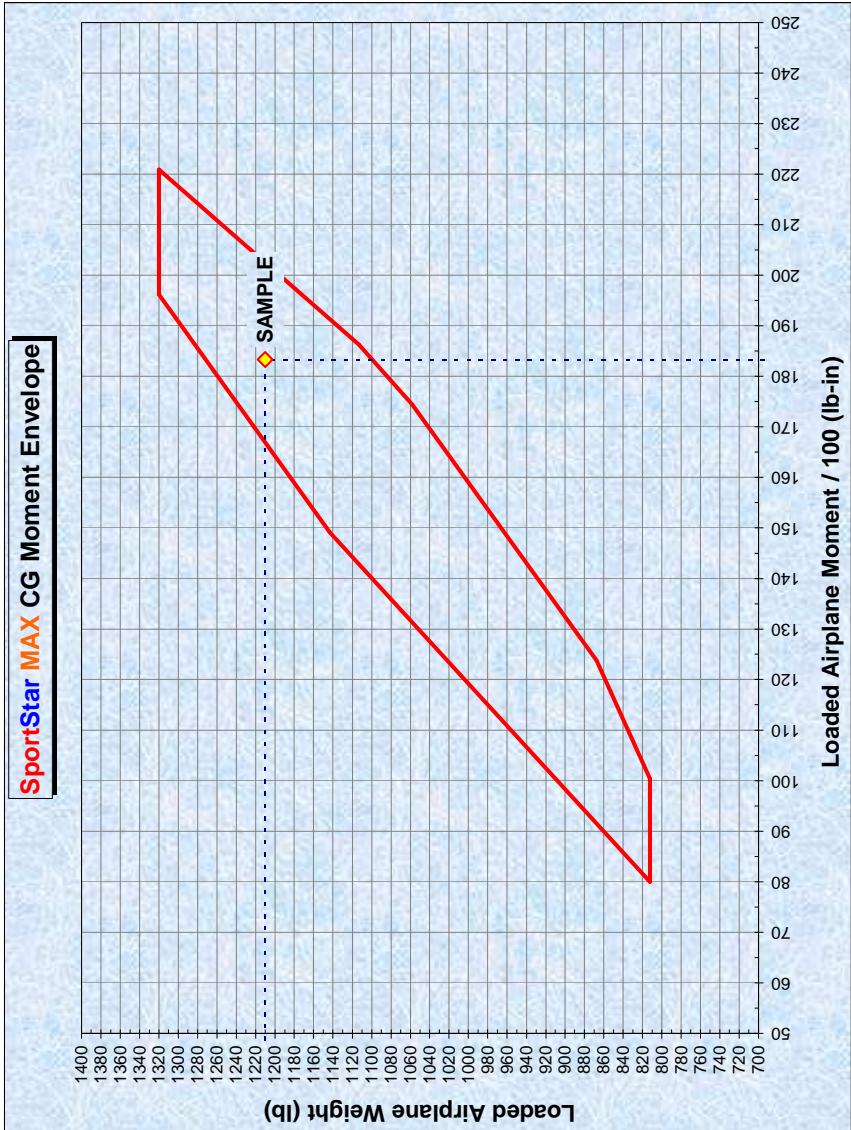



6.9 Operational Weight and CG Envelope

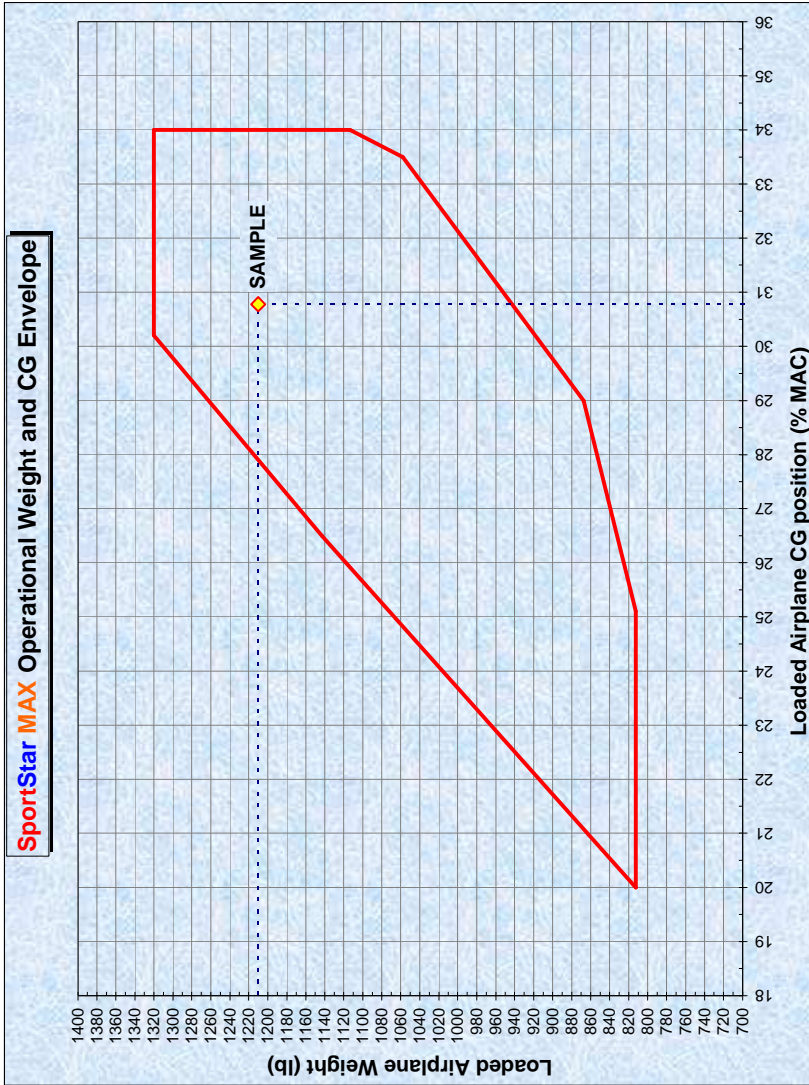



AIRCRAFT OPERATING INSTRUCTIONS

Doc. No. SSM2008AOIUS

6.10 Equipment List

The equipment installed in the airplane of particular serial number is shown in the following Equipment list.

Airplane Serial No.:	2016 1731	Registration	N19EV	Date:
				01/12/2016
Description	Type	Part No.	Manufacturer	Installed
Compass	SIRS NV2C-12V		SIRS	12/14/2015
CDI	GI106A			12/14/2015
DYNON SkyView display	D 1000		DYNON	12/16/2015
DYNON SkyView display	D 700		DYNON	12/16/2015
VHF transceiver	SL30		GARMIN	12/15/2015
Transponder	GTX330		GARMIN	12/15/2015
Intercom	PM3000		PS Engineering	12/14/2015
GPS holder	AIRGIZMOS AERA		AIRGIZMOS	12/16/2015
Altitude encoder	A30			12/13/2015
ELT	AK 451		Ameri King	12/21/2015
Stall warning system	ACI T1			12/16/2015



SECTION 7

7. AIRPLANE AND SYSTEM DESCRIPTION

7.1	Introduction	7-3
7.2	Airframe	7-3
7.2.1	Fuselage	7-3
7.2.2	Wing.....	7-3
7.2.3	Horizontal tail unit (HTU).....	7-3
7.2.4	Vertical tail unit (VTU).....	7-4
7.3	Control	7-4
7.3.1	Longitudinal control.....	7-4
7.3.2	Lateral control	7-4
7.3.3	Rudder control	7-4
7.3.4	Elevator trim tab control	7-5
7.3.5	Aileron trim tab control	7-5
7.4	Controls in cockpit	7-6
7.5	Instrument panel	7-7
7.6	Inside and outside marking and placards	7-7
7.7	Landing gear and brakes	7-7
7.7.1	Landing gear	7-7
7.7.2	Brakes.....	7-7
7.8	Seat and safety harnesses	7-7
7.9	Baggage compartment	7-8
7.10	Canopy	7-8
7.11	Power unit	7-9
7.11.1	General	7-9
7.11.2	Engine control	7-9
7.11.3	Engine instruments.....	7-9
7.11.4	Engine cooling system	7-11
7.11.5	Engine lubrication system.....	7-12
7.11.6	Engine intake system.....	7-12
7.11.7	Ignition system	7-13



7.12 Fuel system	7-13
7.12.1 Fuel tanks.....	7-13
7.12.2 Fuel selector.....	7-13
7.12.3 Fuel filter.....	7-14
7.12.4 Indication of fuel quantity	7-14
7.12.5 Fuel tank draining.....	7-14
7.13 Electrical system.....	7-16
7.13.1 Lighting.....	7-16
7.13.2 Electrical system scheme.....	7-17
7.14 Pitot-static system	7-18
7.15 Supplementary equipment	7-19
7.15.1 Ventilation and heating system	7-19
7.16 Navigation and communication equipment.....	7-19



7.1 Introduction

This section describes systems of the airplane and its operation. More detailed information on optional systems and equipment are available in section 9, Supplements.

7.2 Airframe

The airframe of SportStar MAX airplane is a combination of semimonocoque structure consisting of metal reinforcement, frames and duralumin sheet skin, with a composite back side of fuselage and composite canopy.

7.2.1 Fuselage

The fuselage is a combination of semimonocoque structure consisting of reinforcements and duralumin skin, with a composite back side of fuselage and composite canopy . Fuselage section is rectangular in the lower part and elliptic in the upper part. The fin is an integral part of fuselage. The cockpit for two-member crew is located in the middle part of the fuselage that is accessible after uncovering the single-piece organic glass composite canopy. The engine compartment in the front part of the fuselage is separated from the cockpit by the steel firewall to which the engine bed is attached.

7.2.2 Wing

The wing is of rectangular shape, single-spar structure with the auxiliary spar with suspended ailerons and split wing flaps. Riveting is used for connecting individual structural elements. Fiber-glass wing tips are riveted on the wing ends. There is an integral fuel tank inside each wing half, in the section between the main and auxiliary spar at the wing root.

7.2.3 Horizontal tail unit (HTU)

The VTU of conventional type consists of the stabilizer and elevator with the trim tab. Single-spar structure of HTU consists of duralumin ribs, spar and skin. Top view of HTU is of rectangular shape.



7.2.4 Vertical tail unit (VTU)

VTU is of trapezoidal shape. Its fin is an integral part of the fuselage. The rudder is suspended on the fin by means of two hinges. The VTU structure consists of the duralumin spar and skin.

7.3 Control

Airplane control consists of ailerons, elevator and rudder. Directional control is connected by means of pull rods with nose landing gear control. Main landing gear brakes are controlled by pedals of directional control. Airplane is equipped with dual control enabling flight with two-member crew.

7.3.1 Longitudinal control

Longitudinal control is actuated by the control stick. Longitudinal movement of control stick is transferred to the elevator by mechanical system of pull rods and levers.

7.3.2 Lateral control

Lateral control is actuated by the control stick. From the control stick the movement is transferred through the system of levers and pull rods to ailerons.

7.3.3 Rudder control

Rudder control is controlled by pedals of foot control. The rudder is interconnected with foot control pedals by cable system.

Foot control pedals adjustable into three positions can be installed as an option.

Way of adjustment of ruder pedals:

1. Release the pin from the adjusting groove by pressing lever.
2. Set pedal to required position and release lever.
3. Check on the pin locking-on in the adjusting groove

WARNING
RIGHT AND LEFT PEDAL OF RUDDER
CONTROL MUST BE ADJUSTED IN THE SAME
POSITIONS AND SECURED!

**AIRCRAFT OPERATING INSTRUCTIONS**Doc. No. SSM2008AOIUS

7.3.4 Elevator trim tab control

The elevator trim tab is controlled by the lever located in between the pilot seats. The control lever is interconnected with the trim tab by means of bowdwen-cables.

Electric elevator trim tab control can be installed as an option. Control switches are located on the control stick, trim tab position indicator is located on the instrument panel.

7.3.5 Aileron trim tab control

Electric aileron trim tab control can be installed optionally. Control switches are located on the control stick, trim tab position indicator is located on the instrument panel.



7.4 Controls in cockpit

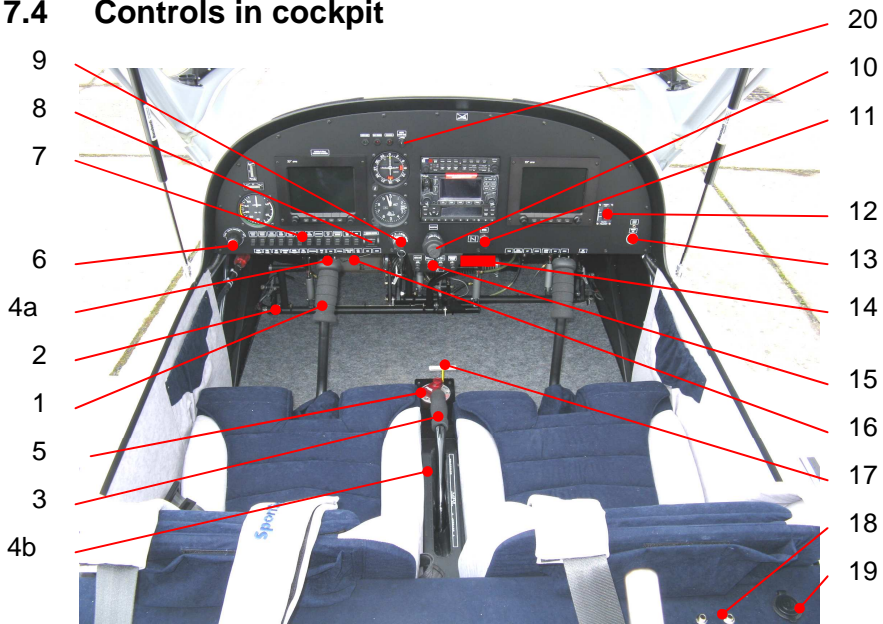

Figure 7–1 Cockpit control elements

1.	Control stick	2.	Rudder pedals
3.	Flap control lever	4.	4a Electric trim (option) 4b Elevator trim control lever
5.	Fuel tank selector	6.	Static pressure selector (option)
7.	Switches (depending on equipment)	8.	Master switch
9.	Switch box	10.	Throttle lever
11.	Choke lever	12.	ELT switch
13.	12V socket	14.	Emergency parachute system lever (option)
15.	Knobs from the left: • Cold air • Hot air • Canopy defog • Carburettor pre-heating	16.	Pop-up breakres (depending on equipment)
17.	Parking brake lever (option)	18.	Headset sockets
19.	Additional 12V socket (option)	20.	Dimmer (option)



7.5 Instrument panel

See Section 9 – Supplements,
Instrument panel is shown in Supplement No. 4 Aircraft Description.

7.6 Inside and outside marking and placards

See Aircraft Maintenance and Inspection Procedures.

7.7 Landing gear and brakes

7.7.1 Landing gear

The airplane is equipped with a sort of fixed nose landing gear. Main landing gear legs are produced from composite spring. Nose landing gear leg is welded from two pieces - the tube and the yoke in which the nose wheel is mounted. The nose landing gear is spring-loaded by a rubber rope. The nose wheel is steerable, wheel control is coupled with rudder control by means of two pull rods. Wheels can be fitted with fiber-glass aerodynamic pants.

7.7.2 Brakes

The SportStar MAX airplane is equipped with disk hydraulic brakes on main landing gear wheels. Brake system is composed of toe-brake pedals (these are a part of rudder control pedals), brake pumps, brake fluid reservoir, brake fluid central bottle on the firewall, hoses for leading brake liquid, brake yokes with wheel cylinders and brake pads. By depressing the brake pedals compression of brake pumps occurs, which generates pressure in brake circuit and hydraulic cylinders press the brake pads onto the brake disks. Braking pressure can be regulated only by force of brake pedals depressing.

The airplane can be equipped by mechanical manually controlled parking brake. PARKING BRAKE handle is located in front of the pilots, on the front wall of the fuel tank selector console.

7.8 Seat and safety harnesses

SportStar MAX is a two-seat airplane with side-by-side seats. Seats are fixed, non-adjustable and fitted with light upholstery.



Each of seats is fitted with four-point safety harness which is composed of safety belts, shoulder straps and lock. The safety harness is anchored in the fuselage sides behind the seats and on the seat sides.

7.9 Baggage compartment

Baggage compartment is positioned behind seat rests. Maximum weight of baggage is 55 lbs (25 kg) and is stated on the placard in the baggage compartment. The baggage compartment is fitted with rubber net for baggage fixation.

WARNING

It is prohibited to use a space behind baggage compartment for additional stowage. This is due to airplane aft C.G. limit.

7.10 Canopy

The cockpit canopy is of a semidrop shape. The framework is composed of composite structure on which the organic glass canopy is stuck.

The canopy is attached to the fuselage in the front part by two swivel pins by means of which it can be folded up forwards. In order to make opening easier, the actual weight of canopy is balanced by two gas struts.

Lock

The canopy is provided with an automotive lock in the rear upper part of the tip-up frame and key lock on the top of rear fixed frame. There is also a canopy open/close sensor installed in the lock, with indication of canopy open position by a red light on the instrument panel or red/green light on a display if a digital instruments like Dynon EFIS/EMS or TruTrak EFIS/EMS are installed.

Maintenance of automotive lock: Spray the lock with WD-40 spray annually from time to time

Check: Check the lock visually for deformations

Adjustment: Release the socket wrench screws on back of the lock, adjust lock position and tight the socket wrench screws



7.11 Power unit

7.11.1 General

The engine ROTAX 912 ULS (100 hp) is standardly used to power SportStar MAX airplane. IFR version is fitted with certified ROTAX 912S.

ROTAX 912 is a four-cylinder, four-stroke engine with opposite cylinders, central cam shaft and OHV valve mechanism.

The on-ground adjustable, composite, 3-blade propeller WOODCOMP KLASSIC 170/3/R is standardly mounted on the engine ROTAX 912 ULS.

IFR version is fitted with ground adjustable, 3-bladed, composite Warpdive CF prop, with Nickel protection of blade leading edges.

Other propeller type can be installed on customer's request - see Section 9 for detailed information .

7.11.2 Engine control

Engine power is controlled by means of THROTTLE lever, which is located in the middle of the instrument panel and which controls engine power range from idle up to maximum take-off. Engine power controller is mechanically interconnected with the flap on carburetters.

If the lever is fully pushed in, then this position corresponds to maximum engine power. If the lever is fully pulled out, then this position corresponds to idle. Rapid changes in engine power setting can be made by pressing down the round button on the lever body and by its pulling out or pushing in. Small changes in power setting can be performed through lever turning (counterclockwise - power increase).

The lever is fitted with the locking ring, counterclockwise turning of which ensures locking of the lever in requested position.

7.11.3 Engine instruments

The following analog instruments located on the instrument panel serve for engine performance monitoring. The digital engine monitoring system can be installed in the airplane instead of analog engine instruments.



RPM indicator

The electrical RPM indicator is controlled by signal from the generator RPM transmitter. Working range of the RPM indicator is 0 - 7000 RPM. Color code is stated in 2.5.

Cylinder head thermometer

The cylinder head thermometer transmitter senses temperature of cylinder No. 3. Working range of the cylinder head thermometer is 120 ÷ 300°F. Color code is stated in 2.5.

Oil thermometer

Oil temperature on engine input is measured by the sensor located behind the oil pump. Working range of oil thermometer is 120 ÷ 300°F. Color code is stated in 2.5.

Oil pressure gauge

Oil pressure on the oil input into engine is measured by means of sensor which is located behind the oil filter. Working range is 0 ÷ 150 PSI. Color code is stated in 2.5.



7.11.4 Engine cooling system

Engine cooling is combined, cylinder heads are cooled by water, cylinders are cooled by air.

Cooling circuit of cylinder heads is designed as a closed system containing pump, expansion reservoir (1) with pressure closure (3), cooler of cooling liquid (2) and drainage reservoir (4). Scheme of cylinder head cooling system is shown in Fig. 7-2.

When changing, the cooling liquid is filled up through the cap of expansion reservoir (1), during airplane operation it is replenished into drainage reservoir (4) between the lines of maximum and minimum level.

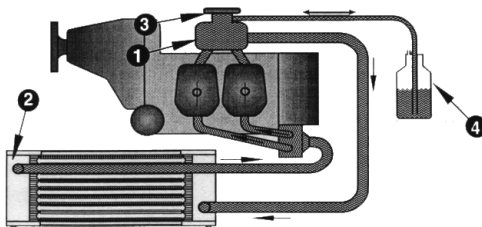

Figure 7-2 Scheme of cylinder head cooling system



7.11.5 Engine lubrication system

Engine lubrication system is performed with the dry crank case. Engine lubrication system is equipped with oil pump (1) ensuring oil feeding from reservoir (4) located on the fire wall through the oil cooler (5) and the oil cleaner (6) to the lubricated points of engine. The pressure sensor (2) is located behind the oil pump. The oil reservoir is aerated by the hose (7) which is led under the airplane. Oil pressure and temperature are indicated on instruments in right side of the instrument panel. Oil is replenished through the lid in the upper part of the oil reservoir.

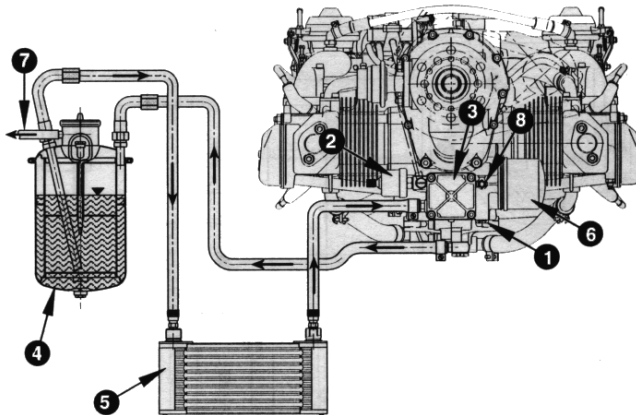

Figure 7-3 Scheme of engine lubrication system

7.11.6 Engine intake system

Engine intake system ensures delivery of sufficient air into engine. Air is taken into the engine through openings on the engine covers through the air filters.

The intake system can be equipped with carburettor heating system. Hot air from the heat exchanger (located on the exhaust collector) is taken to the mixing chamber. Amount of in-taken hot air is regulated by flaps in mixing chamber inlets. Flaps are controlled by the CARBURETTOR PREHEATER knob on the instrument panel.



7.11.7 Ignition system

The engine is equipped with the double contactless ignition system. Each ignition circuit has own source of energy, control unit, 2 ignition coils and 4 spark plugs. It is fully autonomous on the other circuit of accumulator. High voltage current is distributed to the spark plugs through high-voltage cables. Ignition sequence of individual engine cylinders:

Ignition circuits are controlled by the ignition switch on the instrument panel.

Positions of ignition switch:

- OFF engine ignition is off
- R only ignition circuit B is on
- L only ignition circuit A is on
- BOTH both circuits are on
- START both circuits are on and starter is cranking the engine

7.12 Fuel system

Fuel system serves for keeping fuel in the airplane and its feeding to the engine. Fuel system of SportStar MAX airplane is composed of integral fuel tanks, fuel line, fuel selector, fuel filter, mechanical fuel pump - located on the engine (auxiliary electrical fuel pump can be installed), distribution pipe of fuel with, return branch of fuel, fuel gauges and fuel tanks draining valves.

7.12.1 Fuel tanks

Fuel is contained in the wing integral tanks. Each tank is fitted with air venting (output is under the wing tip) and draining valve on the bottom side of the wing. Fuel is led from the tanks through the hoses to the fuel selector located on a central console under the instrument panel and then through a fuel filter to the engine pump and carburetors. Fuel return hose goes from the fuel pump into the left tank, which is due to considered as a "primary" tank. See figure 7-4 for Scheme of fuel system.

7.12.2 Fuel selector

The fuel selector serves for tank selection and fuel delivery interruption in case of engine fire or long parking of airplane. To move selector from OFF (closed) position it necessary pull the safety button on the fuel selector, turn the handle from the OFF position to the left and then release safety button. Now the handle



can be freely moved between LEFT and RIGHT position. Safety button prevents unintentionally switch the selector to OFF position. To move selector to OFF (closed) position it is necessary pull the safety button on the fuel selector, turn the handle to the OFF position and then release safety button. Now the handle is blocked in the OFF position. Safety button prevents unintentionally switch the selector from the OFF position during parking.



7.12.3 Fuel filter

The fuel filter separates all mechanical impurities from fuel. The fuel filter is located in the cockpit on the left airframe panel.

7.12.4 Indication of fuel quantity

Fuel quantity is measured by a float fuel gauge transmitter in each tank and indicated on fuel gauge on the instrument panel. LH fuel gauges indicates fuel quantity in the left (primary) tank, RH indicator in the right tank. True fuel quantity is indicated only on ground and in level flight and it takes approx. 2 minutes to level fuel after transition from climb/descent.

7.12.5 Fuel tank draining

Draining of the fuel tank is specified in Section 8.



AIRCRAFT OPERATING INSTRUCTIONS

Doc. No. SSM2008AOIUS

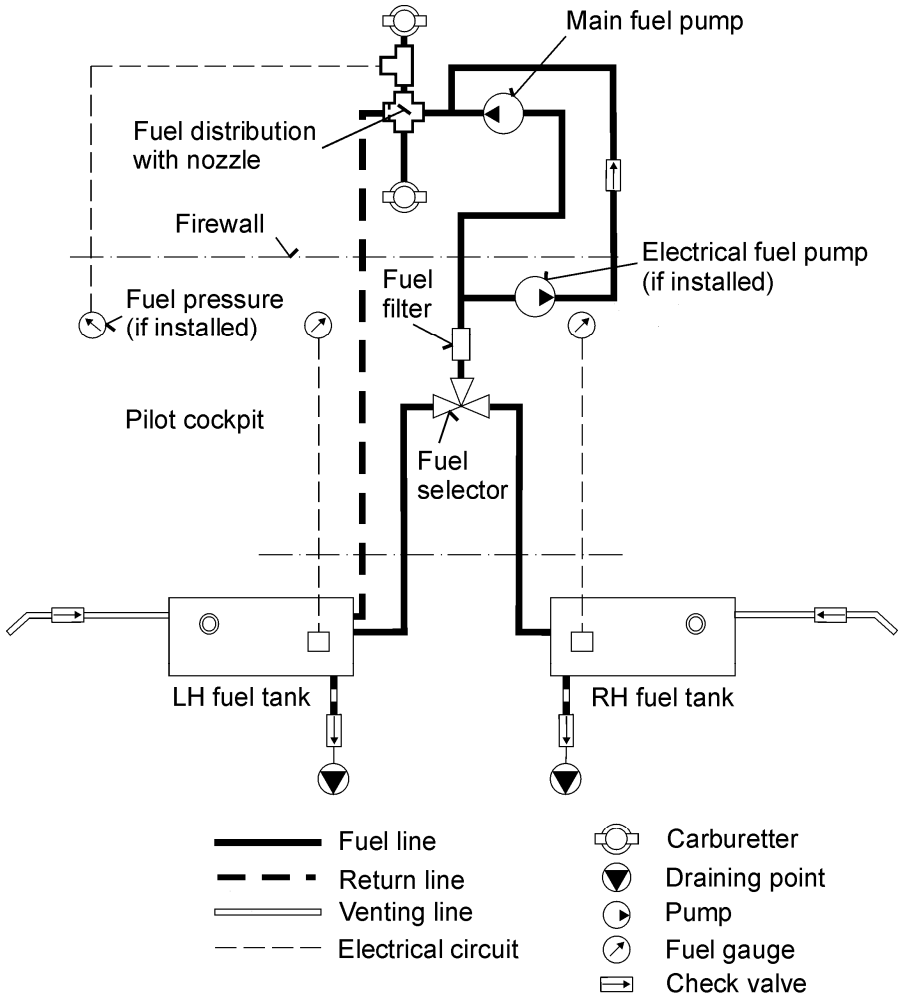

Figure 7-4 Scheme of fuel system



7.13 Electrical system

The airplane is equipped with 14 V DC electrical installation. A generator with power of 250 W is the primary source of electrical energy. The secondary source of energy is the accumulator 12V/16Ah that is located in the engine compartment on the firewall. It is used for engine starting and in case of generator failure as an emergency source of energy and also serves as the smoothing filter of power system.

Widely equipped airplanes (night VFR, IFR) are fitted with the auxiliary generator SD-20, mounted on the engine.

DC voltage is distributed to individual systems by main busbar. Each system is protected by circuit breaker. If overloading of any of the circuits occurs, then the circuit breaker is pulled out. Circuit breakers are listed in the Aircraft Maintenance and Inspection Procedures.

CAUTION

**DO NOT USE CIRCUIT BREAKERS FOR
NORMAL SWITCHING OFF OF THE SYSTEMS**

After switching **MASTER SWITCH** on and by turning the ignition key to **START** position the starter is activated. The starter is power supplied from the accumulator before engine start. After engine has been started and idle RPM reached, generator starts supplying current into electrical network.

Piper type external power socket can be installed optionally. The socket is located on the right side of the fuselage, behind the firewall.

Optionally 12V automotive socket located on the instrument panel can be installed, as well as an another 12V socket behind the co-pilot seat, next to the headphones sockets.

7.13.1 Lighting

Airplane can be equipped with an external lighting.

External lighting can be composed of position lights and anticollision beacons which are located in wing tip and landing headlight which is located in left wing leading edge or in the lower engine cowling. Position lights are switched by **POS. LIGHTS**



AIRCRAFT OPERATING INSTRUCTIONS

Doc. No. SSM2008AOIUS

switch and anticollision beacon by **BEACON** switch. Landing headlight is switched by **LDG LIGHT** switch.

Night VFR and IFR versions are equipped with the landing light, position lights & anticollision beacons. There is also a cockpit light installed for these versions.

7.13.2 Electrical system scheme

See Aircraft Maintenance and Inspection Procedures - Supplements.



7.14 Pitot-static system

Pitot-static tube for sensing static and total pressure is located under the left half of the wing. Total pressure is sensed through the opening in the Pitot-static tube face. Static pressure is sensed through openings on the tube circumference. System of pressure distribution to individual instruments are made by means of flexible plastic hoses. Transparent draining reservoirs are located in the pressure branch of static and total pressure on the left fuselage side on the bottom next to wing leading edge.

Static pressure is led to altimeter, airspeed indicator, variometer and altitude encoder (if installed). Total pressure is led only to the airspeed indicator.

IFR version is equipped with an alternate pitot-static tube located under the right half of the wing. This pitot serves only as a source of alternate static pressure. Both Primary and Alternate pitots are heated. There is a static pressure select knob located on the instrument panel to switch from Primary to Alternate static pressure.

For scheme of IFR pitot-static system refer to IFR Supplement to this AOI.

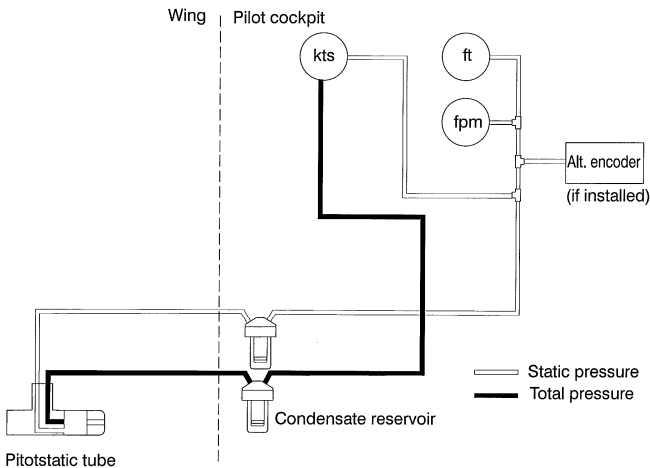

Figure 7-5 Scheme of pitot-static system



7.15 Supplementary equipment

7.15.1 Ventilation and heating system

Cockpit ventilation is ensured by 2 eye-ball vents located on the left and right of the tip-up canopy frame. Vents are connected to the NACA scoops through tip-up canopy frame front flaps.

Cockpit heating is provided by air conducted through a hose guided from a fiberglass collector behind the engine radiator into the heat exchanger and then into the mixture flap on the firewall and further through a directional flap to the cockpit floor or to the hot air outputs through the instrument panel cover as well as into the hollow spaces of the tip-up frame for defrosting. Hot air quantity is regulated by the **HOT AIR** knob, cold air quantity is regulated by the **COLD AIR** knob on the instrument panel. Proportion of the cold and hot air in the heating system can be set continuously. Other knob below the **HOT AIR** knob serves for air routing to the cockpit floor or on the canopy glass.

Defog / defrosting of windshield and sides is ensured by hot air conducted from a cold/hot air mixture flap on the firewall into the tip-up canopy frame and then through a row of holes onto the glass.

7.16 Navigation and communication equipment

Description of operation of navigation and communication equipment see Section 9 - Supplements.



Intentionally left blank



SECTION 8

8. AIRPLANE HANDLING SERVICING AND MAINTENANCE

8.1	Introduction	8-3
8.2	Airplane inspection period	8-5
8.2.1	Airplane Failure Card	8-5
8.3	Modifications or airplane repairs	8-5
8.4	Road transport	8-6
8.4.1	Airplane towing	8-6
8.4.2	Airplane parking	8-6
8.4.3	Airplane anchoring	8-7
8.4.4	Airplane jacking	8-7
8.4.5	Levelling	8-8
8.4.6	Road transport	8-8
8.5	Draining of fuel tank	8-8
8.6	Cleaning and care	8-9



Intentionally left blank



8.1 Introduction

This section includes the procedures for airplane handling, maintenance and operation recommended by the manufacturer.

It is necessary to follow the set-down lubrication plan, scope and periodicity of preventive maintenance depending on climatic and flight conditions according to the Aircraft Maintenance and Inspection Procedures of SportStar MAX Light Sport Aircraft

Airplane owner should be in a permanent touch with the manufacturer, either directly or through the network of business representatives, which enables him to get the newest information concerning airplane operation, handling and maintenance. The manufacturer distributes this information to users through Service bulletins (Mandatory bulletins), Information bulletins (letters) and further instructions.

Mandatory bulletins are especially important for keeping up airworthiness and the manufacturer considers them mandatory although they do not come into effect before Airworthiness Directive is issued by aviation authority of user's country.

All correspondence with the airplane manufacturer, distributor or service center must contain **the airplane serial number**. The airplane serial number is shown on the title sheet of this Instructions and on the Manufacturer's plate below stabilizer on the left side of the fuselage.

The manufacturer delivers along with aircraft SportStar MAX the "Aircraft Operating Instructions (AOI)" and the "Aircraft Maintenance and Inspection Procedures (AMIP)".

Qualification requirements to perform maintenance and repairs are mentioned in the AMIP - item 4.1.1.



Owner/Operator Responsibilities:

- Each owner/operator of an LSA airplane shall read and comply with the maintenance and continued airworthiness information and instructions provided by the manufacturer.
- Each owner/operator of an LSA airplane shall be responsible for providing the manufacturer with current contact information where the manufacturer may send the owner/operator supplemental notification bulletins.
- The owner/operator of an LSA airplane shall be responsible for notifying the manufacturer of any safety of flight issue or significant service difficulty upon discovery.
- The owner/operator of an LSA airplane shall be responsible for complying with all manufacturer issued notices of corrective action and for complying with all applicable aviation authority regulations in regard to maintaining the airworthiness of the LSA airplane.
- An owner of an LSA airplane shall ensure that any needed corrective action must be completed as specified in a notice, or by the next scheduled annual inspection.
- Should an owner/operator not comply with any mandatory service requirement, the LSA airplane shall be considered not in compliance with applicable ASTM Standards and may be subject to regulatory action by the presiding aviation authority.



8.2 Airplane inspection period

Periodical inspections and reviews of airplane must be carried out at the latest in the following intervals:

- after first 25 ± 2 hours of operation
- after every 50 ± 3 hours of operation
- after every 100 ± 5 hours of operation
- annual inspection

Details on periodical inspections are provided in the Aircraft Maintenance and Inspection Procedures of SportStar MAX.

Refer to the Rotax 912 Operator's Manual for engine maintenance. Refer to the Propeller Maintenance Manual for propeller maintenance.

8.2.1 Airplane Failure Card

The Failure Card in Appendix 7 in the Aircraft Maintenance and Inspection Procedures of SportStar MAX is preferably used to report service difficulties.

8.3 Modifications or airplane repairs

USA

§91.327 requires:

(5) Each alteration accomplished after the aircraft's date of manufacture meets the applicable and current consensus standard and has been authorized by either the manufacturer or a person acceptable to the FAA;

(6) Each major alteration to an aircraft product produced under a consensus standard is authorized, performed and inspected in accordance with maintenance and inspection procedures developed by the manufacturer or a person acceptable to the FAA; and

(7) The owner or operator complies with the requirements for the recording of major repairs and major alterations performed on type certificated products in accordance with §43.9 (d) of this chapter, and with the retention requirements in §91.417.

Basic repairs of airplane are described in the Aircraft Maintenance and Inspection Procedures of SportStar MAX.



Road transport

8.4.1 Airplane towing

It is possible to move the airplane on a short distance by holding the fuselage end in the position before the fin, eventually by holding the root part of wings.

The hand towing bar can be used for airplane relocation which will be fastened to the nose wheel axis.

To turn the airplane on the spot, push on the fuselage end part in the area before the fin, lift the nose wheel and turn the airplane in required direction.

WARNING
SWITCH OFF IGNITION BEFORE GROUND
HANDLING WITH THE AIRPLANE!

CAUTION
AVOID EXCESSIVE PRESSURES ON THE
AIRFRAME STRUCTURE, ESPECIALLY ON
THE WING TIPS, HTU, VTU ETC.

WHEN HANDLING THE AIRPLANE BY MEANS
OF THE TOWING BAR, PROPELLER BLADES
MUST BE SET ONE BLADE UP (THREE BLADE
PROPELLER). MAXIMUM DEFLECTION OF
THE NOSE WHEEL IS $\pm 10^\circ$.

AT MANUAL ENGINE STARTING GRASP THE
PROPELLER BLADE AREA, I.E. NOT ONLY
PROPELLER EDGE.

8.4.2 Airplane parking

It is the most suitable solution to place the airplane into a hangar possibly into another covered room with stable temperature, good venting, low humidity and dust-free environment. In case of parking out of the hangar it is necessary to anchor the airplane and at long-term parking to cover the canopy, possibly the whole airplane with suitable tarpaulins.



AIRCRAFT OPERATING INSTRUCTIONS

Doc. No. SSM2008AOIUS

8.4.3 Airplane anchoring

The airplane is anchored at parking out of hangar after termination of flight day or according to need. Anchoring of the airplane is necessary for its protection against possible damage, caused by wings and gusts. For this purpose the airplane is equipped with fixing eyes on the lower side of wings and under the tail skid.

Procedure:

1. Check of fuel selector, off-position of all switches, ignition and master switch.
2. Lock manual control, e.g. by using safety belts
3. Close and lock the cockpit canopy
4. Anchor the airplane to the ground by means of cables pulled through fixing eyes which are located on the lower side of wings. Further it is necessary to anchor the nose landing gear.

NOTE

In case that long-term airplane anchoring is supposed, namely in winter period, it is suitable to cover the canopy, eventually the whole airplane by appropriate tarpaulins which must be properly secured to the airplane structure.

8.4.4 Airplane jacking

Airplane jacking presents no big difficulties due to relatively low airplane empty weight and can be performed by two persons.

First, it is necessary to prepare two suitable rests which will support the airplane.

The airplane can be jacked in the following way:

- by pushing from the above to the fuselage rear part in the position before the fin the front part of fuselage can be jacked and subsequently supported under the fire wall.
- Rear part of fuselage can be slightly jacked only by grasping in the position near the auxiliary skid and by pushing from below and then the lower part of fuselage can be supported by the rest located in the area of the skid.



- Wings can be jacked by pushing on the wing from below in the area of the main spar. It is necessary to avoid jacking by grasping the wing tip.

8.4.5 Levelling

Levelling procedure is described in the Aircraft Maintenance and Inspection Procedures for SportStar MAX airplane.

8.4.6 Road transport

The airplane can be transported on communication after its loading on an appropriate trail. It is necessary to dismount wings. The airplane must be secured against possible movement. This way you will preclude possible damage to the airplane.

8.5 Draining of fuel tank

Draining should be done prior to first flight each day. There is a drain valve of each wing tank located on its bottom.

Procedure:

1. Put a transparent cup under the drain valve.
2. Using screwdriver (or appropriate jig) press and turn drain valve counterclockwise to open it.
3. Drain required quantity of fuel.

NOTE

Draining serves to elimination of impurities and deposits from the fuel. Drain until clean fuel flows from the drain valve.

4. Using screwdriver (or appropriate jig) turn drain valve clockwise to close it.
5. Repeat procedure for the opposite tank.



8.6 Cleaning and care

Always use appropriate cleaning agents when cleaning airplane surface. Residuum of oil and fat can be removed from the airplane surface (excluding the canopy) by suitable detergents, possibly by petrol.

The canopy only to be cleaned by washing with ample stream of tepid water with addition of appropriate detergents. Use soft rag, sponge or wash leather. Use suitable polishing agent after wiping rests of water.

CAUTION

**NEVER DRY-CLEAN THE CANOPY AND
NEVER USE PETROL NOR CHEMICAL
SOLVENTS!**

Coating, upholstery and carpets in the cockpit can be removed from the cockpit, brushed and, if need be, cleaned with warm water with addition of appropriate detergent. Dry up upholstery after doing this.



Intentionally left blank



AIRCRAFT OPERATING INSTRUCTIONS

Doc. No. SSM2008AOIUS

SECTION 9

9. SUPPLEMENTS

9.1	Introduction	9-2
9.2	List of inserted supplements.....	9-2
9.3	Supplements inserted.....	9-4



9.1 Introduction

This section contains the appropriate supplements necessary to safely and efficiently operate the airplane when equipped with various optional systems and equipment not provided with the standard airplane.

9.2 List of inserted supplements

Inst.	Date	Doc. No.	Title of inserted supplement
	March 01/09	SSM2008AOIUSS01	Transceiver KY97A
	March 01/09	SSM2008AOIUSS02	Intercom PM 1000
	March 01/09	SSM2008AOIUSS03	Transponder KT76A
✓	Jan. 10/16	SSM2008AOIUSS04	Airplane description of 2016 1731
	March 01/09	SSM2008AOIUSS05	GPS/COMM receiver KLX 135
	March 01/09	SSM2008AOIUSS06	Flight clock LC-2
	March 01/09	SSM2008AOIUSS07	Transceiver FILSER ATR 600
	March 01/09	SSM2008AOIUSS08	GPS/NAV/COMM receiver GARMIN GNS 430/430A
	March 01/09	SSM2008AOIUSS09	Transponder ATC GARMIN GTX 327
	March 01/09	SSM2008AOIUSS10	Intercom PCD7100-I (PS ENGINEERING INCORPORATED)
	March 01/09	SSM2008AOIUSS11	Rocket activated parachute rescue system Magnum Speed Soft 601
	March 01/09	SSM2008AOIUSS12	Horizon RCA 26
	March 01/09	SSM2008AOIUSS13	Float operation CZAW 1150
	March 01/09	SSM2008AOIUSS14	Horizon LUN 1202
	March 01/09	SSM2008AOIUSS15	Towing gear
✓	March 01/09	SSM2008AOIUSS16	Pitot tube heating
	March 01/09	SSM2008AOIUSS17	Emergency Locator Transmitter AK-450
-	-	SSM2008AOIUSS18	Not used
✓	March 01/09	SSM2008AOIUSS19	Stall warning system ACI type T1b
	March 01/09	SSM2008AOIUSS20	Night VFR operation
	March 01/09	SSM2008AOIUSS21	IFR operation
✓	June 11/14	SSM2008AOIUSS22	DYNON SKYVIEW EFIS/EMS System



9.3 Supplements inserted