

ROTAX[®]
AIRCRAFT ENGINES

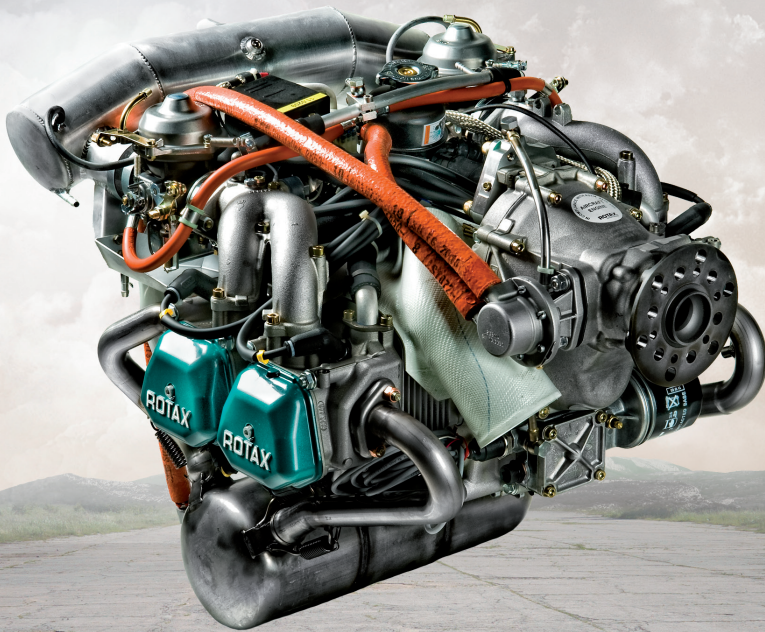

OPERATORS MANUAL

FOR ROTAX[®] ENGINE TYPE 912 SERIES



 **WARNING**

Before starting the engine, read the Operators Manual, as it contains important safety relevant information. Failure to do so may result in personal injuries including death. Consult the original equipment manufacturers handbook for additional instructions!

These technical data and the information embodied therein are the property of BRP-Powertrain GmbH&Co KG, Austria, acc, BGBl 1984 no. 448, and shall not, without prior written permission of BRP-Powertrain GmbH&Co KG, be disclosed in whole or in part to third parties. This legend shall be included on any reproduction of these data, in whole or in part. The Manual must remain with the engine/aircraft in case of sale.

Copyright 2015 © - all rights reserved.

ROTAX[®] is a trade mark of BRP-Powertrain GmbH&Co KG. In the following document the short form of BRP-Powertrain GmbH&Co KG = BRP-Powertrain is used.

Other product names in this documentation are used purely for ease of identification and may be trademarks of the respective company or owner.

Approval of translation has been done to best knowledge and judgement - in any case the original text in English language is authoritative.

Introduction

Foreword

BRP-Powertrain provides “Instructions for Continued Airworthiness”, which are based on the design, the tests and certification of the engine and its components.

These instructions apply only to engines and components supplied by BRP-Powertrain.

This Operators Manual contains important information about safe operation of the engine, together with descriptions of the system and its layout, technical data, operating media and the operational limits of the engine.

The specified data apply only to the engine and not to specific applications in particular aircraft. The aircraft manufacturer’s Operators Manual is therefore definitive in terms of the operation of the engine, as it contains all of the aircraft-specific instructions.

Chapter structure

The structure of the Manual follows whenever it is possible the structure of the „GAMA Specification #1 for Pilot’s Operating Handbook“. The Operators Manual is subdivided into the following chapters:

Subject	Chapter
Introduction	Chapter INTRO
List of effective pages	Chapter LEP)
Table of amendments	Chapter TOA)
General note	Chapter 1)
Operating instructions	Chapter 2)
Standard operation	Chapter 3)
Abnormal operation	Chapter 4)
Performance data	Chapter 5)
Weights	Chapter 6)
Description of systems	Chapter 7)
Checks	Chapter 8)
Supplements	Chapter 9)

NOTES

LEP) List of effective pages

Chapter	Page	Date	Chapter	Page	Date
	cover page				
INTRO	INTRO-1	09 01 2012	4	4-1	02 01 2015
	INTRO-2	09 01 2012		4-2	02 01 2015
LEP	LEP-1	02 01 2015		4-3	02 01 2015
	LEP-2	09 01 2012		4-4	09 01 2012
TOA	TOA-1	02 01 2015		4-5	02 01 2015
	TOA-2	09 01 2012		4-6	02 01 2015
	TOA-3	02 01 2015	5	5-1	09 01 2012
	TOA-4	09 01 2012		5-2	09 01 2012
1	1-1	09 01 2012		5-3	09 01 2012
	1-2	09 01 2012		5-4	09 01 2012
	1-3	09 01 2012		5-5	09 01 2012
	1-4	09 01 2012		5-6	09 01 2012
	1-5	02 01 2015		5-7	09 01 2012
	1-6	09 01 2012		5-8	09 01 2012
	1-7	09 01 2012	6	6-1	09 01 2012
	1-8	09 01 2012		6-2	09 01 2012
	1-9	09 01 2012	7	7-1	09 01 2012
	1-10	04 01 2013		7-2	09 01 2012
1-11	02 01 2015	7-3		09 01 2012	
1-12	09 01 2012	7-4		09 01 2012	
1-13	09 01 2012	7-5		04 01 2013	
1-14	02 01 2015	7-6		09 01 2012	
2	2-1	09 01 2012		7-7	09 01 2012
	2-3	02 01 2015		7-8	09 01 2012
	2-4	09 01 2012		7-9	09 01 2012
	2-5	09 01 2012		7-10	09 01 2012
	2-6	02 01 2015	8	8-1	04 01 2013
	2-7	09 01 2012		8-2	09 01 2012
	2-8	02 01 2015	9	9-1	09 01 2012
	2-9	04 01 2013		9-2	09 01 2012
	2-10	04 01 2013		9-3	09 01 2012
	2-11	09 01 2012		9-4	09 01 2012
2-12	09 01 2012	9-5		09 01 2012	
3	3-1	09 01 2012		9-6	02 01 2015
	3-2	09 01 2012		9-7	02 01 2015
	3-3	09 01 2012		9-8	02 01 2015
	3-4	02 01 2015	rear page		
	3-5	09 01 2012			
	3-6	02 01 2015			
	3-7	09 01 2012			
	3-8	09 01 2012			
3-9	09 01 2012				
3-10	02 01 2015				
3-11	04 01 2013				
3-12	09 01 2012				

d06030.fm

NOTES

TOA) Table of amendments

Approval*

The technical content of this document is approved
under the authority of DOA ref. EASA.21J.048.

current no.	chapter	page	date of change	remark for approval	date of approval from authorities	date of issue	signature
0	1 to 9	all	09 01 2012	DOA*			
1	1	1-5,1-10	04 01 2013	DOA*			
1	2	2-9, 2-10	04 01 2013	DOA*			
1	3	3-6,3-10,3-11	04 01 2013	DOA*			
1	4	4-2, 4-3	04 01 2013	DOA*			
		4-5, 4-6	04 01 2013	DOA*			
1	7	7-5	04 01 2013	DOA*			
1	8	8-1	04 01 2013	DOA*			
2	1	1-5,1-11,1-14	02 01 2015	DOA*			
2	2	2-3, 2-6, 2-8	02 01 2015	DOA*			
2	3	3-4, 3-6, 3-10	02 01 2015	DOA*			
2	4	4-1, 4-2, 4-3,	02 01 2015	DOA*			
2		4-5, 4-6	02 01 2015	DOA*			
2	9	9-6, 9-7, 9-8	02 01 2015	DOA*			

NOTES

TOA) Summary of changes

Content

Summary of the relevant amendments in this context, but makes no claim to completeness.

current no.	chapter	page	date of change	comment
0		cover, rear page	09 01 2012	New layout
0	1	1-4	09 01 2012	Environment note
		1-6	09 01 2012	
0	2	2-4, 2-7	09 01 2012	iRMT
0	3	3-4, 3-7	09 01 2012	Operating limits fuel pressure
0	4	4-2, 4-5	09 01 2012	Engine start
0	9	9-1, 9-3, 9-5, 9-6, 9-7, 9-8	09 01 2012	Engine stop
				Form
				Overview of authorized distributor
1	1	1-5	04 01 2013	Warning: change of text
		1-10	04 01 2013	
1	2	2-9, 2-10	04 01 2013	change of text
1	3	3-6	04 01 2013	change of text
		3-10, 3-11	04 01 2013	change of text
1	4	4-2, 4-3	04 01 2013	Additional text: unscheduled Maintenance
		4-5	04 01 2013	
		4-6	04 01 2013	
1	7	7-5	04 01 2013	oil level, oil pressure at cold start
1	8	8-1	04 01 2013	positioning of text
				Note added
2	1	1-5	02 01 2015	Warning: change of text
2	1	1-11	02 01 2015	
2	1	1-14	02 01 2015	change of Type description
2	2	2-3, 2-6, 2-8	02 01 2015	change of compression ratio.
2	3	3-4, 3-6, 3-10	02 01 2015	Suffix -01 added
2	4	4-1	02 01 2015	change of text
		4-2, 4-5, 4-6	02 01 2015	Additional text: Exceeding of max. admissible coolant temperature
2	9	9-6, 9-7, 9-8	02 01 2015	
				change of text

d06031.fm

NOTES

1) General note

Foreword

Before operating the engine, carefully read this Operators Manual. The Manual provides you with basic information on the safe operation of the engine.

If any passages of the Manual are not clearly understood or in case of any questions, please, contact an authorized Distributor or Service Center for ROTAX aircraft engines.

We wish you much pleasure and satisfaction flying your aircraft with this ROTAX engines.

Table of content

This chapter of the Operators Manual contains general and safety information concerning the operation of the aircraft engine.

Subject	Page
General note	page 1-1
Abbreviations and terms used in this Manual	page 1-3
Safety	page 1-4
Safety notice	page 1-5
Technical documentation	page 1-8
Standard version	page 1-10
Type description	page 1-11
Engine components, engine views, cylinder designation	page 1-12
Technical data	page 1-14
Fuel consumption	page 1-14
Direction of rotation	page 1-14

1.1) General note

Purpose The purpose of this Operators Manual is provided to familiarize the owner/user of this aircraft engine with basic operating instructions and safety information.

Documentation For more detailed information regarding, maintenance, safety- or flight operation, consult the documentation provided by the aircraft manufacturer and/or dealer.

For additional information on engines, maintenance or parts, you can also contact your nearest authorized ROTAX-aircraft engine distributor (Chapter 9.2).

Engine serial number When making inquiries or ordering parts, always indicate the engine serial number, as the manufacturer makes modifications to the engine for product improvement.

The engine serial number is located on the top of the crankcase, magneto side. See Fig. 1.

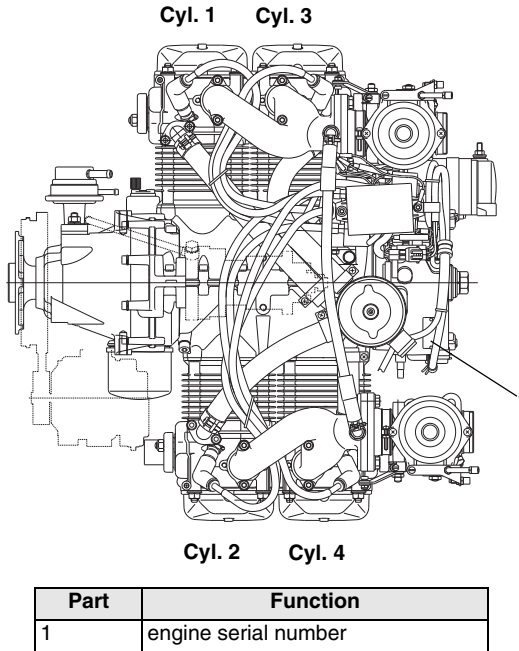

Fig. 1

00334

1.2) Abbreviations and terms used in this Manual

Abbreviations

Abbreviation	Description
°C	Degrees Celsius (Centigrade)
°F	Degrees Fahrenheit
A	Ampere
ACG	Austro Control GmbH
API	American Petrol Institute
ASTM	American Society for Testing and Materials
AKI	Anti Knock Index
CAN/CGSB	Canadian General Standards Board
CW	Clockwise
CCW	Counter-clockwise
DOA	Design Organization Approval
EASA	European Aviation Safety Agency
EN	European Standard
FAR	Federal Aviation Regulations
h	hours
IFR	Instrument Flight Rules
INTRO	Introduction
ISA	International Standard Atmosphere
kW	Kilowatt
LEP	List of effective pages
Nm	Newton meter
OM	Operators Manual
part no.	Part number
RON	Research Octane Number
ROTAX	is a trade mark of BRP-Powertrain GmbH & Co KG
rpm	Revolutions per minute
SAE	Society of Automotive Engineers
SI	Service Instruction
SB	Service Bulletin
SL	Service Letter
TC	Type certificate
TOA	Table of amendments
VFR	Visual Flight Rules

d06032.fm

1.3) Safety

General note

Although the reading of such information does not eliminate the hazard, understanding the information will promote its correct use. Always use common workshop safety practice. The information and components-/system descriptions contained in this Manual are correct at the time of publication. BRP-Powertrain, however, maintains a policy of continuous improvement of its products without imposing upon itself any obligation to install them on its products previously manufactured.

Revision

BRP-Powertrain reserves the right at any time, and without incurring obligation, to remove, replace or discontinue any design, specification, feature or otherwise.

Measuring units

Specifications are given in the SI metric system with the USA equivalent in parenthesis.

Translation

The original English text shall be deemed authoritative.

Symbols used

This Manual uses the following symbols to emphasize particular information. This information is important and must be observed.



Identifies an instruction which, if not followed, may cause serious injury including the possibility of death.



Identifies an instruction which, if not followed, may cause minor or moderate injury.

NOTICE

Denotes an instruction which, if not followed, may severely damage the engine or other component.

ENVIRONMENT NOTE

Environment note gives you tips and behaviors to environmental protection.

NOTES:

Indicates supplementary information which may be needed to fully complete or understand an instruction.



A revision bar outside of the page margin indicates a change to text or graphic.

1.4) Safety notice

Normal use



Non-compliance can result in serious injuries or death!

Never fly the aircraft equipped with this engine at locations, airspeeds, altitudes, or other circumstances from which a successful no-power landing cannot be made, after sudden engine stoppage.

- This engine is not suitable for acrobatics (inverted flight etc.).
- This engine shall not be used on rotorcrafts with an in-flight driven rotor (e.g. helicopters).
- It should be clearly understood that the choice, selection and use of this particular engine on any aircraft is at the sole discretion and responsibility of the aircraft manufacturer, assembler and owner/user.
- Due to the varying designs, equipment and types of aircraft, BRP-Powertrain grants no warranty or representation on the suitability of its engine's use on any particular aircraft. Further, BRP-Powertrain grants no warranty or representation of this engine's suitability with any other part, components or system which may be selected by the aircraft manufacturer, assembler or user for aircraft application.



Non-compliance can result in serious injuries or death!

For each use of DAY VFR, NIGHT VFR or IFR in an aircraft the applicable legal requirements and other existing must be adhered to.

- Certain areas, altitudes and conditions present greater risk than others. The engine may require humidity or dust/sand preventative equipment, or additional maintenance may be required.
- You should be aware that any engine may seize or stall at any time. This could lead to a crash landing and possible severe injury or death. For this reason, we recommend strict compliance with the maintenance and operation and any additional information which may be given to you by your dealer.

- Training**
- Whether you are a qualified pilot or a novice, complete knowledge of the aircraft, its controls and operation is mandatory before venturing solo. Flying any type of aircraft involves a certain amount of risk. Be informed and prepared for any situation or hazard associated with flying.
 - A recognized training program and continued education for piloting an aircraft is absolutely necessary for all aircraft pilots. Make sure you also obtain as much information as possible about your aircraft, its maintenance and operation from your dealer.
 - Engine-specific training courses are authorized by the distributors according to manufacturer specifications (iRMT).
-
- Regulation**
- Respect all government or local rules pertaining to flight operation in your flying area. Fly only when and where conditions, topography, and airspeeds are safest.
 - Consult your aircraft dealer or manufacturer and obtain the necessary information, especially before flying in new areas.
-
- Instrumentation**
- Select and use proper aircraft instrumentation. This instrumentation is not included with the ROTAX engine package. Only approved instrumentation may be installed.
-
- Engine log book**
- Keep an engine log book and respect engine and aircraft maintenance schedules. Keep the engine in top operating condition at all times. Do not operate any aircraft which is not properly maintained or has engine operating irregularities which have not been corrected.
-
- Maintenance (iRMT)**
- Before flight, ensure that all engine controls are operative. Make sure all controls can be easily reached in case of an emergency.
 - Since special tools and equipment may be required, engine servicing should only be performed by an authorized ROTAX engine dealer. BRP-Powertrain requires that any service be carried out and verified by a technician that has a current iRMT rating.

d06032.fm

- When in storage protect the engine and fuel system from contamination and exposure.
-

Engine run

- Never operate the engine without sufficient quantities of operating fluids (oil, coolant, fuel).
 - Never exceed the maximum permitted operational limits.
 - In the interest of safety, the aircraft must not be left unattended while the engine is running.
 - To eliminate possible injury or damage, ensure any loose equipment or tools are properly secured before starting the engine.
 - Allow the engine to cool at idle for several minutes before turning off the engine.
-

Vacuum pump

- This engine may be equipped with a vacuum pump. The safety warning accompanying the vacuum pump must be given to the owner/operator of the aircraft into which the vacuum pump is installed.
-

1.5) Technical documentation

General note These documents form the instructions ensuring continued airworthiness of ROTAX aircraft engines. The information contained is based on data and experience that are considered applicable for skilled mechanics under normal conditions. Due to the fast technical progress and fulfilment of particular specifications of the customers it may occur that existing laws, safety prescriptions, constructional and operational regulations cannot be transferred completely to the object bought, in particular for special constructions, or may not be sufficient.

- Documentation**
- Installation Manual
 - Operators Manual
 - Maintenance Manual (Line and Heavy Maintenance)
 - Overhaul Manual
 - Illustrated Parts Catalog
 - Alert Service Bulletins
 - Service Bulletins
 - Service Instructions
 - Service Letters
-



Status The status of Manuals can be determined with the aid of the table of amendments. The first column indicates the revision state. This figure should be compared with the revision provided on ROTAX-Aircraft Engines Website: www.FLYROTAX.com. Amendments and current versions can be downloaded free of charge.

Revision pages Furthermore the Manual is constructed in such a way that single pages can be replaced instead of the complete document. The list of effective pages is given in the chapter LEP. The particular edition and revision number is given on the footer of each page.

Reference Any reference to a document refers to the latest edition issued by BRP-Powertrain if not stated otherwise.

Illustrations

The illustrations in this Manual are mere sketches and show a typical arrangement. They may not represent the actual part in all its details but depict parts of the same or similar function. Therefore deduction of dimensions or other details from illustrations is not permitted.

NOTE:

The Illustrations in this Manual are stored in a graphic data base system and are provided with a consecutive irrelevant number.

This number (e.g. 00277) is of no significance for the content.

1.6) Standard version

- Serial production**
- 4-stroke, 4 cylinder horizontally opposed, spark ignition engine, single central cam-shaft - push-rods - OHV
 - Liquid cooled cylinder heads
 - Ram air cooled cylinders
 - Dry sump forced lubrication
 - Dual breakerless capacitor discharge ignition
 - 2 constant depression carburetors
 - mechanical fuel pump
 - Electric starter (12 V 0.7 kW)
 - Integrated AC generator with external rectifier-regulator (12 V 20 A DC)
 - Propeller drive via gearbox with integrated mechanical shock absorber and overload clutch

NOTE: The overload clutch is standard equipment on all certified and non-certified aircraft engines with configuration 3.

- Optional**
- Electric starter (12 V 0.9 kW)
 - External alternator (12 V 40 A DC)
 - Vacuum pump (only for A1, A2 and A4 possible)
 - Hydraulic constant speed propeller governor (for configuration 3 only)
-

1.7) Type description

e.g. 912 A 2 -01

The type description is made up the following.

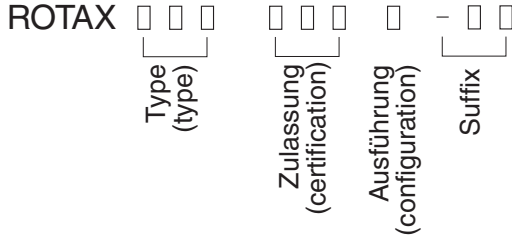

Description

Designation		Description
Type:	912	4-cyl. horizontally opposed, normal aspirated engine
Certification:	A	certified to JAR 22 (TC No. EASA.E.121)
	F, S	certified to FAR 33 (TC No. E00051 EN) JAR-E (TC No. EASA.E.121)
	UL, ULS	non-certified aircraft engines
Configuration	1	Prop shaft with flange for fixed prop, P.C.D 100 mm (3.936 in.)
	2	Prop shaft with flange for fixed pitch propeller.
	3	Prop shaft with flange for constant speed propeller and drive for hydraulic governor for constant speed propeller.
	4	Prop flange for fixed pitch propeller and prepared for retrofit of a hydraulic governor for
Suffix	-XX	Explanation of the type designation Suffix, see SB-912-068.

1.8) Engine components, engine views, cylinder designation

Side view

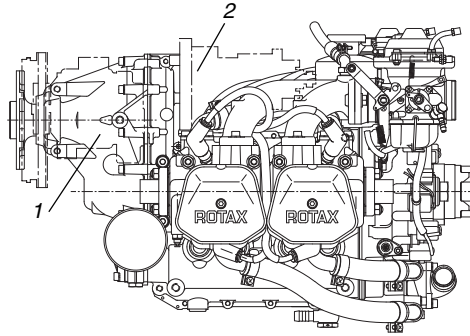

Part	Function
1	Propeller gear box
2	Vacuum pump or hydraulic governor for constant speed propeller

Fig. 2

00337

Top view

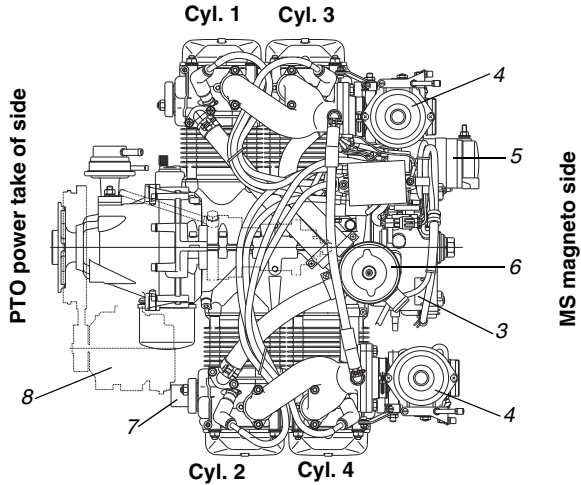

Part	Function
3	Engine serial number
4	CD carburetor
5	Electric starter
6	Expansion tank with excess pressure valve
7	Exhaust flange
8	External alternator

Fig. 3

00334

d06032.fm

Front view

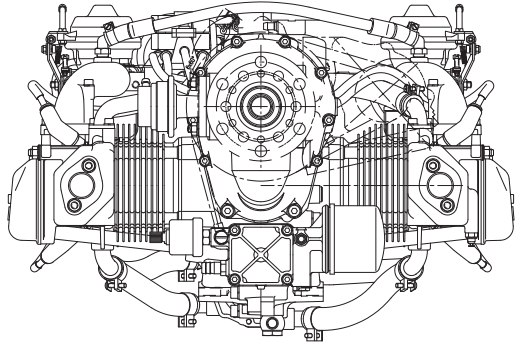

Fig. 4

00336

d06032.fm

1.9) Technical data

See table

Description	912 A/F/UL	912 S/ULS
Bore	79.5 mm (3.13 in)	84 mm (3.31 in)
Stroke	61 mm (2.40 in)	61 mm (2.40 in)
Displacement	1211 cm ³ (73.9 in ³)	1352 cm ³ (82.5 in ³)
Compression ratio.	9.0 : 1	10.8: 1

1.10) Fuel consumption

See table

Fuel consumption in l/h (US gal/h)	912 A/F/UL	912 S/ULS
At take-off performance	24.0 l/h (6.3 gal/h)	27.0 l/h (7.1 gal/h)
At max. continuous performance	22.6 l/h (5.6 gal/h)	25.0 l/h (6.6 gal/h)
At 75 % continuous performance	16.2 l/h (4.3 gal/h)	18.5 l/h (4.9 gal/h)
Specific consumption at max. continuous performance	285 g/kWh (0.47 lb/hph)	285 g/kWh (0.47 lb/hph)

1.11) Direction of rotation

Direction of rotation on propeller shaft

Direction of rotation on propeller shaft: counter clockwise, looking at p.t.o side of engine.

normal direction of propeller rotation (engine)

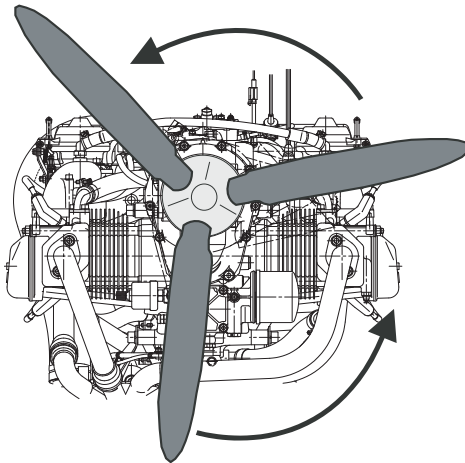

Fig. 5

08629

d06032.fm

2) Operating instructions

Introduction

The data of the certified engines are based on type certificate of type 912 A JAR 22 (TC No. EASA.E.121), 912 F/S FAR 33 (TC No. E00051 EN), JAR-E (TC No. EASA.E.121).

Table of contents

This chapter of the Operators Manual contains the operating limits that must be observed to ensure the ROTAX aircraft engine and standard systems operate safely.

Subject	Page
Operating limits (912 A/F/UL)	page 2-2
Performance	page 2-2
Speed	page 2-2
Acceleration	page 2-2
Oil pressure	page 2-2
Oil temperature	page 2-2
EGT	page 2-2
Conventional coolant	page 2-3
Waterless coolant	page 2-3
Engine start temperature	page 2-4
Fuel pressure	page 2-4
Power consumption of the hydraulic propeller governor	page 2-4
Power consumption of the vacuum pump	page 2-4
Power consumption of the external alternator	page 2-4
Deviation from bank angle	page 2-4
Operating limits (912 S/ULS)	page 2-5
Performance	page 2-5
Speed	page 2-5
Acceleration	page 2-5
Oil pressure	page 2-5
Oil temperature	page 2-5
EGT	page 2-5
Conventional coolant	page 2-6
Waterless coolant	page 2-6
Engine start temperature	page 2-7
Fuel pressure	page 2-7
Power consumption of the hydraulic propeller governor	page 2-7
Power consumption of the vacuum pump	page 2-7
Power consumption of the external alternator	page 2-7
Deviation from bank angle	page 2-7
Operating fluids:	page 2-8
Coolant	page 2-8
Fuel	page 2-9
Lubricants	page 2-10

d06033.fm

2.1) Operating limits (912 A/F/UL)

Performance Performance data relate to ISA (International Standard Atmosphere) conditions without Governor, external alternator etc.

Take-off performance	59.6 kW at 5800 rpm
Max. continuous performance	58 kW at 5500 rpm

Speed

Take-off speed	5800 rpm (max. 5 min)
Max. continuous speed	5500 rpm
Idle speed	min. 1400 rpm

Acceleration

Limit of engine operation at zero gravity and in **negative "g"** condition.

Max.	5 seconds at max. -0.5 g
------	--------------------------

Oil pressure

Max.	7 bar (102 psi)
NOTICE For a short period admissible at cold start.	
Min.	0.8 bar (12 psi) (below 3500 rpm) * 1.5 bar (22 psi)
Normal	2.0 to 5.0 bar (29-73 psi) (above 3500 rpm) * 1.5 to *5.0 bar (22-73 psi) * 912 UL to S/N 4,402.387 912 A to S/N 4,410.266 912 F to S/N 4,412.764

Oil temperature

Max.	140 °C (285 °F)
Min.	50 °C (120 °F)
normal operating temperature	approx. 90 to 110 °C (190 - 230 °F)

EGT

exhaust gas temperature

Max.	880 °C (1616 °F)
------	------------------

d06033.fm

Conventional coolant

See also [Chapter 2.3](#).

Applicable for engine S/N without Suffix -01.

Coolant temperature: (coolant exit temperature)	
Max.	120 °C (248 °F)

Cylinder head temperature:	
Max.	150 °C (300 °F)
Permanent monitoring of coolant temperature and cylinder head temperature is necessary.	

Waterless coolant

See also [Chapter 2.3](#).

Cylinder head temperature:	
Max.	150 °C (300 °F)
Permanent monitoring of cylinder head temperature is necessary.	

Conventional coolant

Applicable for engine S/N with Suffix -01.

Coolant temperature limit measured in the cylinder head	Engine type
Max. 120 °C (248 °F)	912 A/F/UL
Permanent monitoring of coolant temperature is necessary.	

Engine start, operating temperature

Max.	50 °C (120 °F) (ambient temperature)
Min.	-25 °C (-13 °F) (oil temperature)

Fuel pressure**WARNING**

Non-compliance can result in serious injuries or death!

Exceeding the max. admissible fuel pressure will override the float valve of the carburetor and to engine failure.

The aircraft engine manufacturer strongly recommends the installation of an additional pump, unless this has not been covered by legal obligations so far.

Max.	0.4 bar (5.8 psi) (0.5 bar (7.26 psi))*
Min.	0.15 bar (2.2 psi)

* applicable only for fuel pump from S/N 11.0036

Propeller governor

Power consumption of the hydraulic propeller governor:	
Max.	600 W

Vacuum pump

Power consumption of the vacuum pump:	
Max.	300 W

External alternator

Power consumption of the external alternator:	
Max.	1200 W

Bank angle

Deviation from bank angle:	
Max.	40°

NOTE: Up to this value the dry sump lubrication system warrants lubrication in every flight situation.

2.2) Operating limits (912 S/ULS)

Performance Performance data relate to ISA (International Standard Atmosphere) conditions without Governor, external alternator etc.

Take-off performance	73.5 kW at 5800 rpm
Max. continuous performance	69 kW at 5500 rpm

Speed

Take-off speed	5800 rpm (max. 5 min)
Max. continuous speed	5500 rpm
Idle speed	min. 1400 rpm

Acceleration

Limit of engine operation at zero gravity and in **negative "g"** condition.

Max.	5 seconds at max. -0.5 g
------	--------------------------

Oil pressure

Max.	7 bar (102 psi)
NOTICE	For a short period admissible at cold start.
Min.	0.8 bar (12 psi) (below 3500 rpm)
Normal	2.0 to 5.0 bar (29-73 psi) (above 3500 rpm)

Oil temperature

Max.	130 °C (266 °F)
Min.	50 °C (120 °F)
normal operating temperature	approx. 90 to 110 °C (190-230 °F)

EGT

exhaust gas temperature

Max.	880 °C (1616 °F)
------	------------------

Conventional coolant

See also [Chapter 2.3](#)).

Applicable for engine S/N without Suffix -01.

Coolant temperature: (coolant exit temperature)	
Max.	120 °C (248 °F)

Cylinder head temperature:	
Max.	135 °C (275 °F)
Permanent monitoring of coolant temperature and cylinder head temperature is necessary.	

Waterless coolant

Cylinder head temperature:	
Max.	135 °C (275 °F)
Permanent monitoring of cylinder head temperature is necessary.	

Conventional coolant

Applicable for engine S/N with Suffix -01.

Coolant temperature limit measured in the cylinder head	Engine type
Max. 120 °C (248 °F)	912 S/ULS
Permanent monitoring of coolant temperature is necessary.	

Engine start, operating temperature

Max.	50 °C (120 °F) (ambient temperature)
Min.	-25 °C (-13 °F) (oil temperature)

Fuel pressure

Non-compliance can result in serious injuries or death!

Exceeding the max. admissible fuel pressure will override the float valve of the carburetor and to engine failure.

The aircraft engine manufacturer strongly recommends the installation of an additional pump, unless this has not been covered by legal obligations so far.

Max.	0.4 bar (5.8 psi) (0.5 bar (7.26 psi))*
Min.	0.15 bar (2.2 psi)

* applicable only for fuel pump from S/N 11.0036

Propeller governor

Power consumption of the hydraulic propeller governor:	
Max.	600 W

Vacuum pump

Power consumption of the vacuum pump:	
Max.	300 W

External alternator

Power consumption of the external alternator:	
Max.	1200 W

Bank angle

Deviation from bank angle:	
Max.	40°

NOTE: Up to this value the dry sump lubrication system warrants lubrication in every flight situation.

2.3) Operating media-Coolant

General note

NOTICE

Obey the latest edition of Service Instruction SI-912-016 for the selection of the correct coolant.

Conventional coolant

Conventional coolant mixed with water has the advantage of a higher specific thermal capacity than water-less coolant.

Application

When correctly applied, there is sufficient protection against vapor bubble formation, freezing or thickening of the coolant within the operating limits.

Use the coolant specified in the manufacturers documentation.

Mixture

NOTICE

Obey the manufacturers instructions about the coolant.

Applicable for engine S/N without Suffix -01.

designation	mixture ratio %	
	concentrate	water
conventional e.g. BASF Glysantine anticorrosion	50*	50
waterless e.g. Aero Cool 180°	100	0

* coolant component can be increased up to max. 65%.

Applicable for engine S/N with Suffix -01.

designation	mixture ratio %	
	concentrate	water
conventional e.g. BASF Glysantine anticorrosion	50*	50

* coolant component can be increased up to max. 65%.

2.4) Operating media-Fuel

General note

NOTICE

Obey the local codes and the latest edition of Service Instruction SI-912-016 for the selection of the correct fuel.

NOTICE

Use only fuel suitable for the respective climatic zone.

NOTE: Risk of vapour formation if using winter fuel for summer operation.

Knock resistance

The fuels with following specifications can be used:

Fuel specifikationen		
	Usage/Description	
Knock resistance	912 A/F/UL	912 S/ULS
		Min. RON 90 (min. AKI* 87)

* Anti Knock Index (RON+MON)/2

MOGAS

	Usage/Description	
Mogas	912 A/F/UL	912 S/ULS
European standard	EN 228 Normal	
	EN 228 Super	EN 228 Super
	EN 228 Super plus	EN 228 Super plus

AVGAS

AVGAS 100LL places greater stress on the valve seats due to its high lead content and forms increased deposits in the combustion chamber and lead sediments in the oil system.

	Usage/Description	
AVGAS	912 A/F/UL	912 S/ULS
Aviation Standard	AVGAS 100 LL (ASTM D910)	AVGAS 100 LL (ASTM D910)

2.5) Operating media-Lubricants

General note

NOTICE

Obey the manufacturers instructions about the lubricants.
If the engine is mainly run on AVGAS more frequent oil changes will be required. See Service Information SI-912-016, latest edition.

Oil type

For the selection of suitable lubricants refer to the Service Information SI-912-016, latest edition.

Oil consumption

Max. 0.06 l/h (0.13 liq pt/h).

Oil specification

- Use only oil with API classification "**SG**" or higher!
- Due to the high stresses in the reduction gears, oils with gear additives such as high performance motor cycle oils are required.
- Because of the incorporated overload clutch, oils with friction modifier additives are unsuitable as this could result in a slipping clutch during normal operation.
- Heavy duty 4-stroke motor cycle oils meet all the requirements. These oils are normally not mineral oils but semi- or full synthetic oils.
- Oils primarily for Diesel engines have **insufficient high temperature properties and additives which favour clutch slipping, and are generally unsuitable.**

Oil viscosity

Use of multi-grade oils is recommended.

NOTE:

Multi-viscosity grade oils are less sensitive to temperature variations than single grade oils.

They are suitable for use throughout the seasons, ensure rapid lubrication of all engine components at cold start and get less fluid at higher temperatures.

Table of lubricants See Fig. 1

Since the temperature range of neighboring SAE grades overlap, there is no need for change of oil viscosity at short duration of ambient temperature fluctuations.

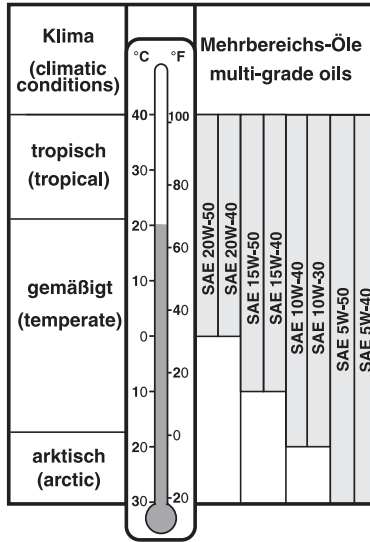

Fig. 1

06317

NOTES

3) Standard operation

Introduction

To warrant reliability and efficiency of the engine, meet and carefully observe all the operating and maintenance instructions.

Table of content

This chapter of the Operators Manual contains expanded operating and maintenance instructions.

Subject	Page
Daily checks	page 3-2
Coolant level	page 3-3
Check of mechanical components	page 3-4
Gear box	page 3-4
Carburetor	page 3-4
Exhaust system	page 3-4
Before engine start	page 3-5
Pre-flight checks	page 3-5
Operating media	page 3-5
Coolant	page 3-5
Oil	page 3-6
Oil level (oil dipstick)	page 3-6
Engine start	page 3-7
Prior to take-off	page 3-9
Warming up period	page 3-9
Throttle response	page 3-9
Ignition check	page 3-9
Propeller governor	page 3-9
Take-off	page 3-10
Cruising	page 3-10
Engine shut-off	page 3-10
Cold weather operation	page 3-11

3.1) Daily checks

General note

To warrant reliability and efficiency of the engine, meet and carefully observe all the operating and maintenance instructions.



Risk of burnings and scalds!
Hot engine parts!
Conduct checks on the cold engine only!



Non-compliance can result in serious injuries or death!

Ignition “OFF”

Before moving the propeller switch off both ignition circuit and secure the aircraft. Have the cockpit occupied by a competent person.

 **NOTICE**

If established abnormalities (e.g. excessive resistance of the engine, noise etc.) inspection in accordance with the relevant Maintenance Manual is necessary. Do not release the engine into service before rectification.

Coolant level

NOTICE

The coolant specifications of the section [Chapter 2.3](#)) Operating media are to be observed!

Step	Procedure
1	Verify coolant level in the expansion tank , replenish as required up to top. The max. coolant level must be flush with the bottom of the filterneck (see Fig. 1).
2	Verify coolant level in the overflow bottle , replenish as required. The coolant level must be between max. and min. mark.

Graphic

Expansion tank

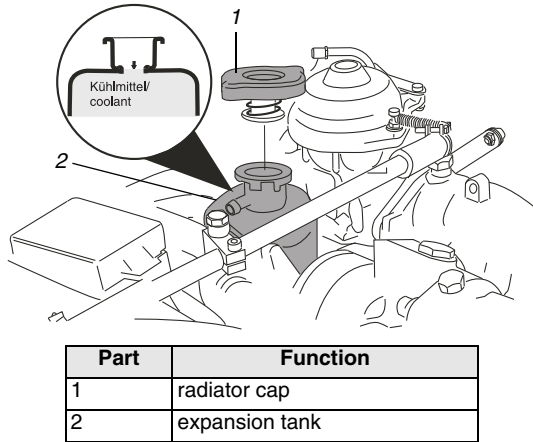

Fig. 1

05823

Check of mech. components

Check of mechanical components

Step	Procedure
1	Turn propeller by hand in direction of engine rotation several times and observe engine for odd noises or excessive resistance and normal compression.

NOTICE

At excessive resistance of the engine perform the relevant unscheduled maintenance check according to Maintenance Manual (Line), chapter “Hard to turn over“.

Gear box

Version without overload clutch:

No further checks are necessary.

Version with overload clutch:

Step	Procedure
1	Turn the propeller by hand to and fro, feeling the free rotation of 30° before the crankshaft starts to rotate. If propeller can be turned between the dogs frictionless (lower than 25 Nm (19 ft.lb)), further inspection is required.

Carburetor

Step	Procedure
1	Verify free movement of throttle cable and starting carburetor over the complete range. Check from the cockpit.

Exhaust system

Step	Procedure
1	Inspect for damages, leakage and general condition.

3.2) Before engine start

Carry out pre-flight checks.

3.3) Pre-flight checks

Safety



Non-compliance can result in serious injuries or death!

Ignition “OFF”. Before moving the propeller. Switch off both ignition circuits and anchor the aircraft. Have the cockpit occupied by a competent person.



Risk of burnings and scalds!

Hot engine parts!

Carry out pre-flight checks on the cold or luke warm engine only!

Operating media

Step	Procedure
1	Check for any oil-, coolant- and fuel leaks. If leaks are evident, rectify and repair them before next flight.

Coolant

The coolant specifications of the section [Chapter 2.3](#)) Operating media are to be observed!

Step	Procedure
1	Verify coolant level in the overflow bottle , replenish as required up to top. The coolant level must be between min. and max. mark.

NOTICE

The oil specifications of the section [Chapter 2.5](#)) Operating media are to be observed!

Step	Procedure
1	Check oil level and replenish as required.
2	<p>NOTE: Propeller shouldn't be turned excessively reverse the normal direction of engine rotation.</p> <p>Remove bayonet cap, turn the propeller slowly by hand in direction of engine rotation several times to pump oil from the engine into the oil tank.</p>
3	It is essential to build up compression in the combustion chamber. Maintain the pressure for a few seconds to let the gas flow via the piston rings into the crankcase. The speed of rotation is not important but the pressure and the amount of gas which is transferred into the crankcase
4	This process is finished when air is returning back to the oil tank and can be noticed by a gurgle from the open oil tank.
5	Install bayonet cap.

Oil level (oil dipstick)

NOTE: The oil level should be in the upper half (between the "50%" and the "max" mark) and should never falls below the "min" mark. Prior to long flights oil should be added so that the oil level reaches the "max" mark.

Avoid oil levels exceeding the "max" mark, since excess oil could be poured out through the venting system.

Difference between max.- and min.- mark = 0.45 litre (0.95 liq pt).

3.4) Engine start

Safety



Non-compliance can result in serious injuries or death!

Do not take the engine into operation if any person is near the aircraft.

Engine start

Step	Designation	Procedure
1	Fuel valve	open
2	Starting carb	activated
	If engine in operating temperature	Then start the engine without choke
3	Throttle lever	set to idle position
4	Master switch	ON
5	Ignition	both circuits switched on
	NOTICE	Do not actuate starter button (switch) as long as the engine is running. Wait until complete stop of engine!
6	Starter button	actuate
	NOTICE	Activate starter for max. 10 sec. only (without interruption), followed by a cooling period of 2 minutes!
7	As soon as engine runs	adjust throttle to achieve smooth running at approx. 2500 r.p.m
8	Oil pressure	Check if oil pressure has risen within 10 seconds and monitor oil pressure. Increase of engine speed is only permitted at steady oil pressure readings above 2 bar (30 psi).
9	NOTICE	At an engine start with low oil temperature, continue to observe the oil pressure as it could drop again due to the increased flow resistance in the suction line. The number of revolutions may be only so far increased that the oil pressure remains steady.
10	Starting carb (choke)	de-activate

To observe!

Reduction gear with shock absorber

NOTICE

Since the engine comprises a reduction gear with shock absorber, take special care of the following:

Step	Procedure
1	To prevent impact load, start with throttle lever in idle position or at the most up to 10% open.
2	For the same reason, wait for around 3 sec. after throttling back to partial load to reach constant speed before re-acceleration.
3	For checking the two ignition circuits, only one circuit may be switched off and on at a time.

3.5) Prior to take-off

Safety



Non-compliance can result in serious injuries or death!

Do not take the engine into operation if any person is near the aircraft.

Warming up period

Step	Procedure
1	Start warming up period at approx. 2000 rpm for approx. 2 minutes.
2	Continue at 2500 rpm, duration depending on ambient temperature, until oil temperature reaches 50 °C (120 °F).
3	Check temperatures and pressures.

Throttle response

NOTICE

After a full-load ground test allow a short cooling run to prevent vapour formation in the cylinder head.

Step	Procedure
1	Short full throttle ground test (consult Aircraft Operators Manual since engine speed depends on the propeller used).

Ignition check

Check the two ignition circuits at **4000 rpm** (approx. 1700 rpm propeller).

Step	Procedure
1	Speed drop with only one ignition circuit must not exceed 300 rpm (approx. 130 rpm propeller).
2	115 rpm (approx. 50 rpm propeller) max. difference of speed by use of either circuit, A or B.
	NOTE: The propeller speed depends on the actual reduction ratio.

Propeller governor

Check of hydraulic propeller governor:

Check control of the hydraulic propeller governor to specifications of the manufacturer.

NOTE: Cycling the propeller governor puts a relatively high load on the engine. Unnecessary cycling should be avoided.

3.6) Take-off

Safety



Non-compliance can result in serious injuries or death!

- Oil temperature, cylinder head temperature, coolant temperature and oil pressure has to be observed. Limits must not be exceeded!
See [Chapter 2.1](#)) Operating limits.
- Respect “cold weather operation” recommendations, see [Chapter 3.9](#)).

Climb

Climbing with engine running at take-off performance is permissible (max. 5 minutes) (see [Chapter 2.1](#)).

3.7) Cruising

Performance

Step	Procedure
1	Set performance as per performance specifications Chapter 5) and respect operating limits as per Chapter 2.1).

Oil temperature

Step	Procedure
1	Avoid operation below normal operation oil temperature (90 to 110 °C / 194 to 230 °F), as possible formation of condensation water in the lubrication system badly influences the oil quality. To evaporate possibly accumulated condensation water, at least once a day 100 °C (212 °F) oil temperature must be reached.

3.8) Engine shut-off

General note

Normally the cooling down of the engine during descending and taxiing will be sufficient to allow the engine to be shut off as soon as the aircraft is stopped.

At increased operating temperatures make an engine cooling run of at least minimum 2 minutes.

3.9) Cold weather operation

General note Generally, an engine service should be carried out before the start of the cold season.

Coolant For selection of coolant and mixing ratio, see "Coolant", [Chapter 2.3](#)

Lubricant For selection of oil, see table of Lubricants [Chapter 2.5](#)).

- Cold start**
- With throttle closed and choke activated (open throttle renders starting carb ineffective).
 - Be aware, no spark below crankshaft speed of 220 rpm (propeller speed of 90 rpm).
 - As performance of electric starter is greatly reduced when hot, limit starting to periods not much longer than 10 sec. With a well charged battery, adding a second battery will not improve cold starts.

Remedy - Cold start

Step	Procedure
1	Use of multigrade oil with the low end viscosity code of 5 or 10.
2	Check electrode gap of spark plugs and set it to the minimum or fit new spark plugs.
3	Preheat engine.

Icing in the air intake system

Icing due to humidity

Carburetor icing due to humidity may occur on the venturi and on the throttle valve due to fuel evaporation and leads to performance loss and change in mixture.

- Remedy**
- Intake air pre-heating is the only effective remedy. See Flight Manual supplied by the aircraft manufacturer.
-

**Icing due to water
in fuel**

Icing due to water in fuel

NOTICE

Fuels containing alcohol always carry a small amount of water in solution. In case of temperature changes or increase of alcohol content, water or a mixture of alcohol and water may settle and could cause troubles.

Water in fuel will accumulate at the lower parts of the fuel system and leads to freezing of fuel lines, filters or jets.

Remedy

- Use non-contaminated fuel (filtered through suede)
 - Generously sized water separators
 - Fuel lines routing inclined
 - Prevent condensation of humidity, i.e avoid temperature differences between aircraft and fuel.
-

4) Abnormal operation

Introduction



Non-compliance can result in serious injuries or death!

At unusual engine behaviour conduct checks as per Maintenance Manual, Chapter 05-50-00 before the next flight.

NOTE: Further checks - see Maintenance Manual.

Table of contents

This chapter of the Operators Manual contains expanded operating and maintenance instruction at abnormal operation.

Subject	Page
Start during flight	page 4-2
Exceeding of max. admissible engine speed	page 4-2
Exceeding of max. admissible cyl. head temperature	page 4-2
Exceeding of max. admissible cooling system temperature	page 4-2
Exceeding of max. admissible oil temperature	page 4-3
Oil pressure below minimum - during flight	page 4-3
Oil pressure below minimum - on ground	page 4-3
Trouble shooting	page 4-4

4.1) Start during flight

- Engine stop**
- If the propeller turns in flight cause of windmilling, but its speed is not sufficient to start the engine, then the electric starter is easily usable.
It is never ever necessary to wait for the standstill of the propeller.
-

4.2) Exceeding of max. admissible engine speed

- Exceeding of max. engine speed**
- Reduce engine speed. Any exceeding of the max. admissible engine speed has to be entered by the pilot into the logbook, stating the duration and extend of overspeed.
 - Carry out an unscheduled maintenance check according to Maintenance Manual Line chapt. 05-50-00.
-

4.3) Exceeding of max. admissible cooling system temperature

Exceeding of cooling system temperature

NOTICE

Reduce engine power setting to the minimum necessary to maintain flight and carry out precautionary landing.

4.3.1) Exceeding of max. admissible cyl. head temperature

Applicable for engine S/N without Suffix -01.

- Any exceeding of the max. admissible cylinder head temperature has to be entered by the pilot into the logbook, stating duration and extent of over-temperature condition.
 - Carry out an unscheduled maintenance check according to Maintenance Manual Line chapt. 05-50-00.
-

4.3.2) Exceeding of max. admissible coolant temperature

Applicable for engine S/N with Suffix -01.

- Any exceeding of the max. admissible coolant temperature has to be entered by the pilot into the logbook, stating duration and extent of over-temperature condition.
 - Carry out an unscheduled maintenance check according to Maintenance Manual Line chapt. 05-50-00.
-

4.4) Exceeding of max. admissible oil temperature

Exceeding of oil temperature

NOTICE

Reduce engine power setting to the minimum necessary to maintain flight and carry out precautionary landing.

- Any exceeding of the max. oil temperature must be entered by the pilot in the logbook, stating duration and extent of over-temperature condition.
 - Carry out an unscheduled maintenance check according to Maintenance Manual Line chapt. 05-50-00.
-

4.5) Oil pressure below minimum - during flight

Oil pressure below minimum

NOTICE

Reduce engine power setting to the minimum necessary and carry out precautionary landing.

- Check oil system.
 - Carry out an unscheduled maintenance check according to Maintenance Manual Line chapt. 05-50-00.
-

4.6) Oil pressure below minimum - on ground

Immediately stop the engine and check for reason. Check oil system.

- Check oil quantity in oil tank.
 - Check oil quality. See [Chapter 2.5](#)).
 - Carry out an unscheduled maintenance check according to Maintenance Manual Line chapt. 05-50-00.
-

4.7) Trouble shooting

Introduction

All checks in accordance with the Maintenance Manual (current issue/revision).



Non-compliance can result in serious injuries or death!

Only qualified staff (authorized by the Aviation Authorities) trained on this particular engine, is allowed to carry out maintenance and repair work.

NOTICE

If the following hints regarding remedy do not solve the problem, contact an authorized workshop. The engine must not be operated until the problem is rectified.

Table of content

This chapter of the Operators Manual contains possible cause and remedy in case of trouble shooting.

Subject	Page
Starting problems	page 4-5
Engine run	page 4-5
Oil pressure	page 4-5
Oil level	page 4-6
Engine hard to start at low temperature	page 4-6

Starting problems**Engine does not start**

Possible cause	Remedy
Ignition off.	Switch on.
Closed fuel valve or clogged filter.	Open valve, clean or renew filter, check fuel system for leaks.
No fuel in tank.	Refuel.
Starting speed too low, faulty or discharged battery.	Fit fully charged battery.
Starting speed too low, start problems on cold engine.	Use top quality, low friction oil; allow for sufficient cooling period to counter for performance drop on hot starter; pre-heat engine.
Wrong fuel (Jetfuel or Diesel).	Change of fuel.

Engine run**Engine idles rough after warm-up period, smoky exhaust emission**

Possible cause	Remedy
Starting carb (Choke) activated.	Close starting carb (Choke).

Engine keeps running with ignition off

Possible cause	Remedy
Overheating of engine.	Let engine cool down at idling at approx. 2000 rpm.

Knocking under load

Possible cause	Remedy
Octane rating of fuel too low.	Use fuel with higher octane rating.

Oil pressure**Low oil pressure**

Possible cause	Remedy
Not enough oil in oil tank.	Refill oil.
Too hot oil.	Cool down oil.

High oil pressure

Possible cause	Remedy
Too cold oil.	Cover oil cooler or install thermostat.
Wrong viscosity of oil.	Change oil to lower viscosity.

Oil level

Oil level is increasing

Possible cause	Remedy
Oil too cold during engine operation.	Cover oil cooler surface, observe the operating limits.
Contamination with diesel fuel.	Check fuel

Cold engine start

Engine hard to start at low temperature

Possible cause	Remedy
Starting speed too low.	Preheat engine.
Low charge battery.	Fit fully charged battery.
High oil pressure.	At cold start a pressure reading of up to around 7 bar (102 psi) does not indicate a malfunction.
Oil pressure too low after cold start.	Too much resistance in the oil suction system at low temperatures due to cold oil. Stop engine and preheat oil. After a cold start the oil pressure must be observed and should be above 1.5 bar (22 psi). Otherwise, the speed must be lowered again, because not enough cold oil can be sucked. If oil pressure is lower than 1 bar (15 psi) oils with lower viscosity have to be used. See SI-912-016, current issue.
NOTE:	Oil pressure must be measured at idle at an oil temperature of minimum 50 °C (120 °F). Be sure the oil pressure does not go below minimum at idle.

d06035.fm

5) Performance data

Introduction

The performance tables and performance graphs on the next few pages are intended to show you what kind of performance to expect from your engine in terms of power output. The indicated power can be achieved by following the procedures laid out in the Operators Manual and ensuring that the engine is well-maintained.

Table of content

This chapter of the Operators Manual contains performance table and performance graphs.

Subject	Page
Engine type 912 A/F/UL	page 5-2
Performance graphs for stand. conditions	page 5-2
Performance data for variable pitch propeller	page 5-3
Performance graph for non-standard conditions	page 5-4
Engine type 912 S/ULS	page 5-5
Performance graphs for stand. conditions	page 5-5
Performance data for variable pitch propeller	page 5-6
Performance graph for non-standard conditions	page 5-7

Performance graphs for stand. conditions (ISA)

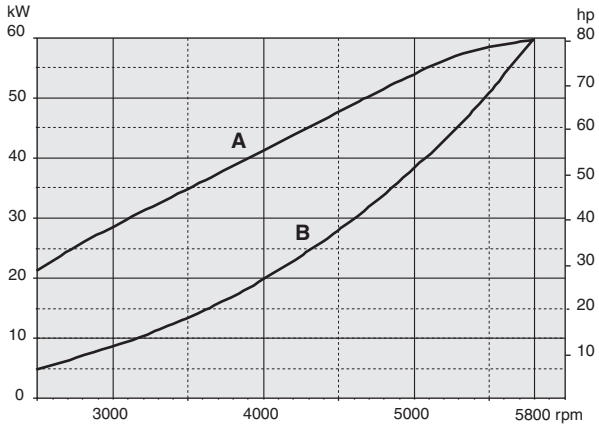

A: max. engine output
B: power requirement of propeller

Fig. 1

00450

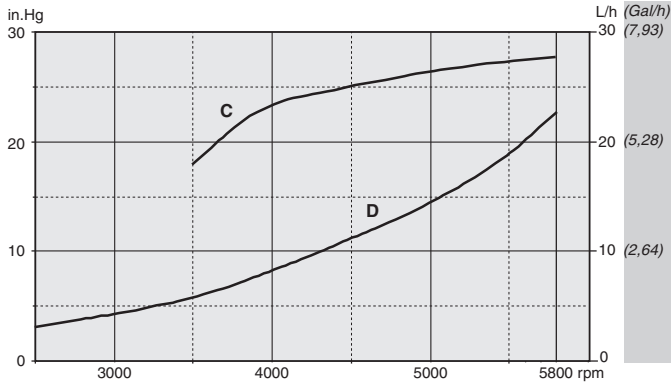

C: manifold pressure
D: fuel consumption

Values along propeller curve

Fig. 2

00451

Performance data for variable pitch propeller

Engine speed over 5500 rpm is restricted to 5 minutes.

Run the engine in accordance with the following table.

Power setting	Engine speed (rpm)	Performance (kW)/(HP)		Torque (Nm) (ft.lb)		Manifold pressure (in.HG)
Take-off power	5800	59.6	80	98.1	72.35 ft.lb	full throttle
max. continuous power	5500	58.0	78	100.7	74.27 ft.lb	full throttle
75 %	5000	43.5	58	83.1	61.29 ft.lb	27.2
65 %	4800	37.7	50	75.0	55.32 ft.lb	26.5
55 %	4300	31.9	43	70.8	52.22 ft.lb	26.3

NOTE: Further essential information regarding engine behavior see Service Letter SL-912-016, latest edition.

Performance data variable pitch propeller

The following graph shows the performance drop with increasing flight altitude. The curves show the performance at 5800, 5500, 5000, 4500 and 4000 rpm, at full throttle.

At deviation of temperature conditions from standard atmosphere conditions the engine performance to be expected can be calculated from the performance indicated, multiplied by standard temperature, divided by actual temperature in K.

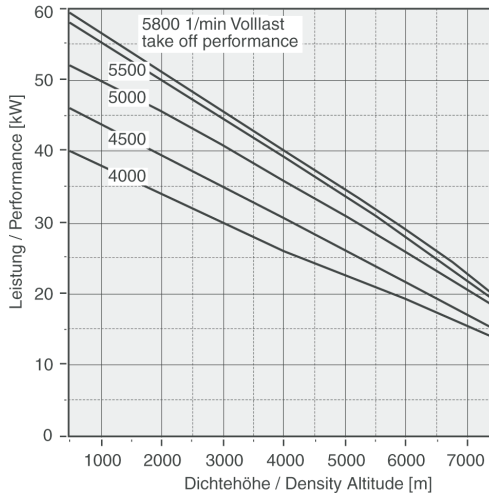

$$P_{\text{akt.}} = P_{\text{stand.}} \cdot \frac{T_{\text{standard}}}{T_{\text{aktuell}}}$$
$$T [\text{K}] = t [^{\circ}\text{C}] + 273$$

Fig. 3

08635

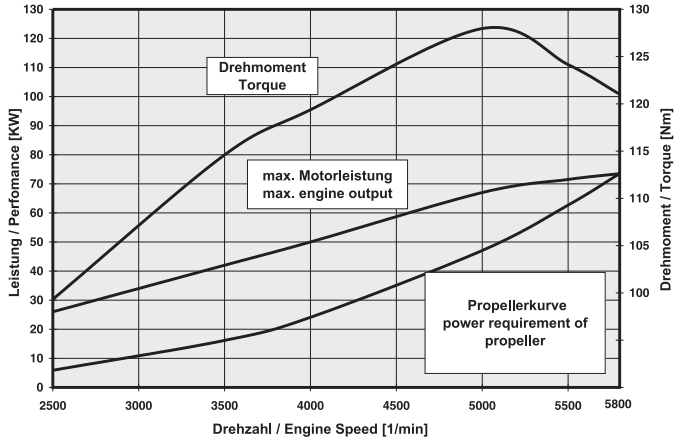

Fig. 4

02001

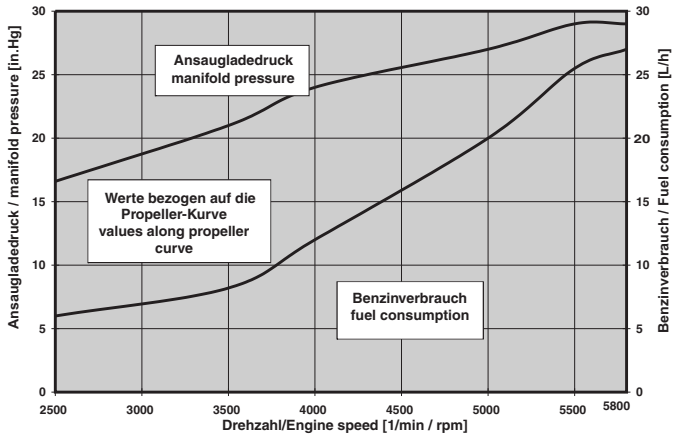

Fig. 5

02002

d05479.fm

Performance data for variable pitch propeller

Engine speed over 5500 rpm is restricted to 5 minutes.

Run the engine in accordance with the following table.

Power setting	Engine speed (rpm)	Performance (kW)/(HP)	Torque (Nm) (ft.lb)		Manifold pressure (in.HG)
Take-off power	5800	73.5/100	121.0	89.24 ft.lb	27.5
max. continuous power	5500	69.0/90	119.8	88.36 ft.lb	27
75 %	5000	51.0/68	97.4	71.84 ft.lb	26
65 %	4800	44.6/60	88.7	65.42 ft.lb	26
55 %	4300	38.0/50	84.3	62.17 ft.lb	24

NOTE: Further essential information regarding engine behavior see Service Letter SL-912-016, latest edition.

Performance graph for non-standard conditions

The following graph shows the performance drop with increasing flight altitude. The curves show the performance at 5800, 5500, 5000, 4800 and 4300 rpm, at full throttle.

At deviation of temperature conditions from standard atmosphere conditions the engine performance to be expected can be calculated from the performance indicated, multiplied by standard temperature, divided by actual temperature in °K.

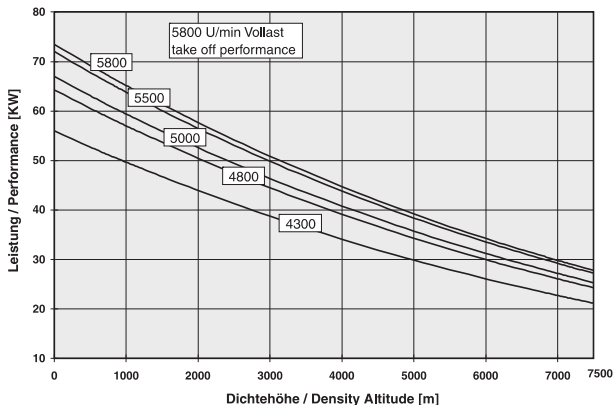

$$P_{\text{akt.}} = P_{\text{stand.}} \cdot \frac{T_{\text{standard}}}{T_{\text{aktuell}}}$$

$$T \text{ [K]} = t \text{ [}^\circ\text{C]} + 273$$

Fig. 6

08636

NOTES

6) Weights

Introduction

The stated weights are dry weights (without operating fluids) and are guide values only.

Further weight information relating to the equipment can be found in the current Installation Manual.

Table of content

This chapter of the Operators Manual contains an extensive list of approved equipment for this engine.

Subject	Page
Engine	page 6-2
Accessories	page 6-2

6.1) Engine

- **with:** electric starter, carburetors, internal generator, ignition unit and oil tank
- **without:** exhaust system, radiator, airbox

Configuration 2				
912 UL	912 A	912 F	912 ULS	912 S
57.1 kg (126 lb) with overload clutch	57.1 kg (126 lb)	57.1 kg (126 lb)	58.3 kg (128 lb) with overload clutch	58.3 kg (128 lb)
55.4 kg (122 lb) without clutch			56.6 kg (125 lb) without clutch	

Configuration 3				
912 UL	912 A	912 F	912 ULS	912 S
59.8 kg (132 lb)			61 kg (134 lb)	

6.2) Accessories

Part	Weight
External alternator	3.0 kg (6.6 lb)
Vacuum pump	0.8 kg (1.8 lb)
Overload clutch	1.7 kg (3.7 lb)
NOTE:	The overload clutch is installed on all certified aircraft engines and on non-certified aircraft engines of the configuration 3.

7) Description of systems

Introduction

This chapter of the Operator Manual contains the description of cooling system, fuel system, lubrication system, electric system and the propeller gearbox.

Table of content

As already mentioned in the preface, the system descriptions only apply to the engine, not to a specific application in a particular aircraft. The aircraft manufacturers Operators Manual is therefore definitive in terms of the operation of the engine, as it contains all the aircraft specific instructions.

Subject	Page
Cooling system of engine	page 7-2
Coolant	page 7-2
Expansions tank	page 7-2
Coolant temperature measuring	page 7-2
Fuel system	page 7-4
Fuel	page 7-4
Return line	page 7-4
Lubrication system	page 7-5
Lubrication	page 7-5
Crankcase	page 7-5
Oil pump	page 7-5
Oil circuit vented	page 7-5
Oil temperature sensor	page 7-5
Electric system	page 7-7
Charging coils	page 7-7
Propeller gearbox	page 7-8
Reduction ratio	page 7-8
Overload clutch	page 7-8
Torsional shock absorber	page 7-8
Backlash	page 7-9
Vacuum pump	page 7-9

7.1) Cooling system of the engine

General note

See Fig. 1.

Cooling

The cooling system of the engine is designed for liquid cooling of the cylinder heads and ram-air cooling of the cylinders. The cooling system of the cylinder heads is a **closed** circuit with an expansion tank.

Coolant

The coolant flow is forced by a water pump, driven from the camshaft, from the radiator to the cylinder heads. From the top of the cylinder heads the coolant passes on to the expansion tank (1). Since the standard location of the radiator (2) is below engine level, the expansion tank located on top of the engine allows for coolant expansion.

Expansion tank

The expansion tank is closed by a pressure cap (3) (with excess pressure valve and return valve). At temperature rise of the coolant the excess pressure valve opens and the coolant will flow via a hose at atmospheric pressure to the transparent overflow bottle (4). When cooling down, the coolant will be sucked back into the cooling circuit.

Coolant temperature measuring

Readings are taken on measuring point of the hottest cylinder head, depending on engine installation.

NOTE: The temperature sensors are located in cylinder head 2 and 3.

Cooling system

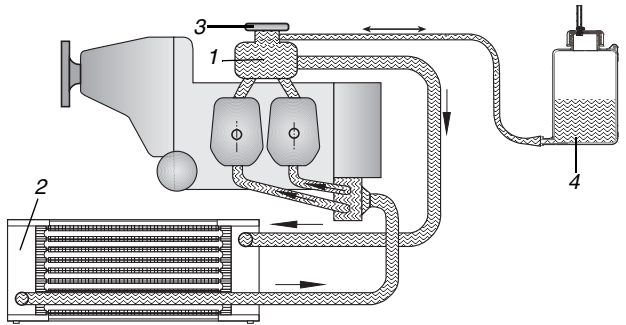

Part	Function
1	Expansion tank
2	Radiator
3	Pressure cap
4	Overflow bottle

Fig. 1

09152

7.2) Fuel system

General note

See Fig. 2

Fuel

The fuel flows from the tank (1) via a coarse filter (2) the fire cock (3) and fine filter (4) to the mechanical fuel pump (5). From the pump fuel passes on via the fuel manifold (6) to the two carburetors.

Return line

Via the return line surplus fuel flows back to the fuel tank and suction side of fuel system.

NOTE: The returnline serves to avoid formation of vapour lock.

Fuel system

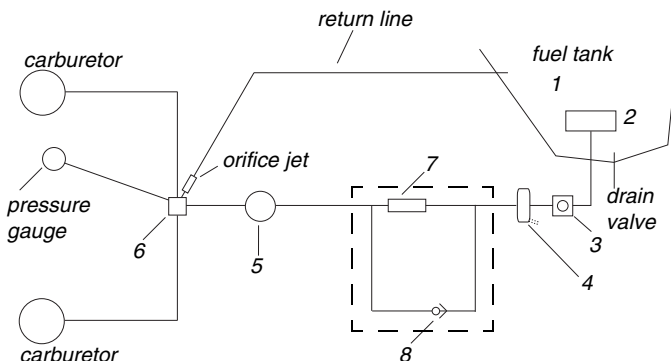

Part	Function
1	Fuel tank
2	Coarse filter
3	Fire cock
4	Fine filter
5	Mechanical fuel pump*
6	Fuel manifold*
7	Electric fuel pump
8	Check valve
	* standard configuration

Fig. 2

07306

d05671.fm

7.3) Lubrication system

General note	See Fig. 3 The engines are provided with a dry sump forced lubrication system with a main oil pump with integrated pressure regulator (1) and oil pressure sensor (2).
Lubrication	The oil pump (3) sucks the motor oil from the oil tank (4) via the oil cooler (5) and forces it through the oil filter (6) to the points of lubrication in the engine
Crankcase	The surplus oil emerging from the points of lubrication accumulates on the bottom of crankcase and is forced back to the oil tank by the piston blow-by gases.
Oil pump	The oil pumps are driven by the camshaft.
Oil venting system	The oil circuit is vented via bore (7) on the oil tank.
Oil temperature sensor	The oil temperature sensor (8) for reading of the oil inlet temperature is located on the oil pump housing.

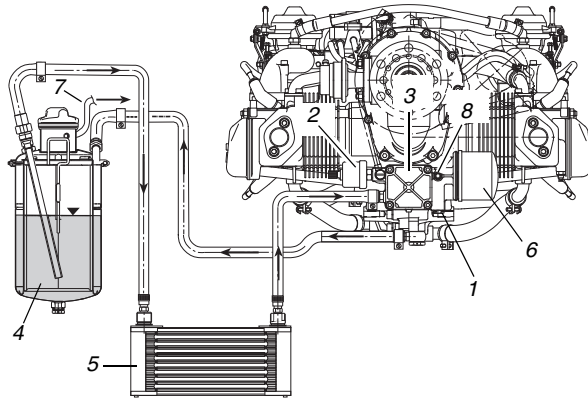

Part	Function
1	Pressure regulator
2	Oil pressure sensor
3	Oil pump
4	Oil tank
5	Oil cooler
6	Oil filter
7	Venting tube
8	Oil temperature sensor

Fig. 3

08650

7.4) Electric system

General note

See Fig. 4

The ROTAX 912 engine is equipped with a dual ignition unit of a breakerless, capacitor discharge design, with an integrated generator.

The ignition unit needs no external power supply.

Charging coils

Two independent charging coils (1) located on the generator stator supply one ignition circuit each. The energy is stored in capacitors of the electronic modules (2). At the moment of ignition 2 each of the 4 external trigger coils (3) actuate the discharge of the capacitors via the primary circuit of the dual ignition coils (4).

NOTE: The trigger coil (5) is provided for rev counter signal.

Firing order: 1-4-2-3.

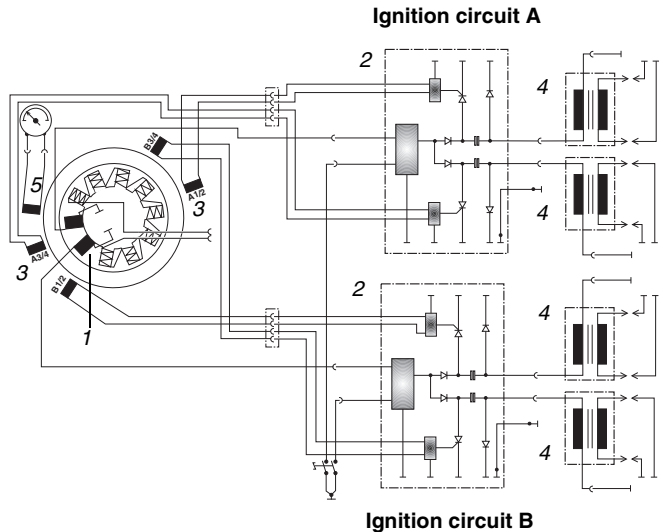

Part	Function
1	Charging coils
2	Electronic modules
3	Trigger coils for ignition signal
4	Dual ignition coils
5	Trigger coils for speed signal

Fig. 4

00425

d05671.fm

7.5) Propeller gearbox

General note

See Fig. 5

Reduction ratio

For the engine type 912 two reduction ratios are available.

Reduction ratio	912 A/F/UL	912 S/ULS
crankshaft: propeller shaft	2.27:1	2.43:1
	2.43:1 (optional)	

Overload clutch

Depending on engine type, certification and configuration the propeller gearbox is supplied with or without an overload clutch.

NOTE: The overload clutch is installed on serial production on all certified aircraft engines and on the non-certified aircraft engines of configuration 3.

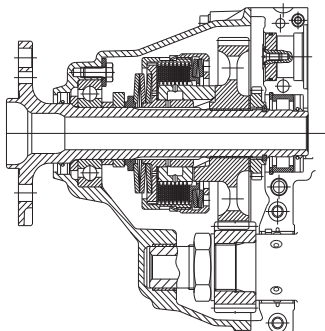

Fig. 5

02531

NOTE: Fig. shows a propeller gearbox of configuration 2 with the integrated overload clutch.

Torsional shock absorber

The design incorporates a torsional shock absorber. The shock absorbing is based on progressive torsional cushioning due to axial spring load acting on a dog hub.

Backlash

On the gearbox version with overload clutch the design incorporates a friction damped free play at the dogs to warrant proper engine idling. Due to this backlash at the dogs a distinct torsional impact arises at start, stop and at sudden load changes, but due to the built-in overload clutch it will remain harmless.

NOTE: This overload clutch will also prevent any undue load to the crankshaft in case of ground contact of the propeller. See Service Letter SL-912-015, latest edition.

Vacuum pump or hydraulic governor

Alternatively either a vacuum pump **or** a hydraulic governor for constant speed propeller can be used. The drive is in each case via the propeller reduction gear.

NOTES

8) Checks

Introduction

All checks to be carried out as specified in the current Maintenance Manual (last revision).

 **WARNING**

Non-compliance can result in serious injuries or death!

Only qualified staff (authorized by the Aviation Authorities) trained on this particular engine, is allowed to carry out maintenance and repair work.

NOTE:

Further useful information about service and airworthiness of your engine is also available on **www.rotax-owner.com**.

NOTICE

Carry out all directives of Service Bulletins (SB), according to their **priority**.
Observe according Service Instructions (SI) and Service Letter (SL).

Table of content

This chapter of the Operators Manual contains checks of the aircraft engines.

Subject	Page
Engine preservation	page 8-2
Engine back to operation	page 8-2

8.1) Engine preservation

General note



Risk of burnings and scalds!

Hot engine parts!

Always allow engine to cool down to ambient temperature before start of any work.

Due to the special material of the cylinder wall, there is no need for extra protection against corrosion for the ROTAX aircraft engines. At extreme climatic conditions and for long out of service periods we recommend the following to protect the valve guides against corrosion:

Step	Procedure
1	Operate the engine until the temperatures have stabilized for a period of 5 min (engine oil temperature between 50 to 70 °C (122 to 160 °F)).
2	Switch the engine OFF.
3	Allow the engine to cool down.
4	Change oil.
5	Remove the air intake filters and insert approx. 30 cm ³ (1 fl oz) of corrosion inhibiting oil into the carburetor throat with the engine running at increased idle speed. Shut off engine.
6	Drain carburetor float chamber.
7	Apply oil to all joints on carburetors.
8	Close all openings on the cold engine, such as exhaust end pipe, venting tube, air filter etc. against entry of dirt and humidity.
9	Spray all steel external engine parts with corrosion inhibiting oil.

8.2) Engine back to operation

If preservation (including oil change) took place within a year of storage, oil renewal will not be necessary. For longer storage periods repeat preservation annually.

Step	Procedure
1	Remove all plugs and caps.
2	Clean spark plugs with plastic brush and solvent.
3	Reinstall.

d05672.fm

9) Supplement

Introduction

According to the regulation of EASA part 21 A.3 / FAR 21.3 the manufacturer shall evaluate field information and report to the authority. In case of any relevant occurrences that may involve malfunction of the engine, the form on the next page should be filled out and sent to the responsible authorized ROTAX® distributor.

NOTE: The form is also available from the official ROTAX® AIRCRAFT ENGINES Website in electronic version.

www.FLYROTAX.com

Table of content

This chapter of the Operators Manual contains the form and the list of authorized distributors for ROTAX aircraft engines.

Subject	Page
Form	page 9-3
Authorized distributors	page 9-5

NOTES

9.1) Form

d06036.fm

 CUSTOMER SERVICE INFORMATION REPORT		OPER. Control No.			
		ATA Code			
Enter pertinent data		1. A/C Reg. No.			
2. AIRCRAFT	MANUFACTURER	MODEL/SERIES	SERIAL NUMBER		
3. POWERPLANT	ROTAX				
4. PROPELLER					
5. SPECIFIC PART (of component) CAUSING TROUBLE					
Part Name	MFG. Model or Part No.	Serial No.	Part/Defect Location		
6. ENGINE COMPONENT (Assembly that includes part)					
Engine/Comp. Name	Manufacturer	Model or Part No.	Serial Number		
Engine TSN	Engine TSO	Engine Condition	7. Date Sub.		
8. Comments (Describe the malfunction or defect and the circumstances under which it occurred. State probable cause and recommendations to prevent recurrence.)					REP. STA <input type="checkbox"/> OPER <input type="checkbox"/> MECH <input type="checkbox"/> AIR TAXI <input type="checkbox"/> MFG <input type="checkbox"/> ACG <input type="checkbox"/> COMPUTER <input type="checkbox"/> OTHER <input type="checkbox"/> DISTRICT OFFICE
					OPERATOR DESIGNATOR SUBMITTED BY:
TELEPHONE NUMBER: () _____					

Optional Information:

Check a box below, if this report is related to an aircraft

Accident; Date
 Incident; Date

NOTES

9.2) Authorized Distributor

General note See the official ROTAX® AIRCRAFT ENGINES Website
www.FLYROTAX.com

List Overview of authorized distributor for ROTAX aircraft engines.

Subject	Page
Europe	page 9-6
America Australia Africa	page 9-7 page 9-7 page 9-7
Asia	page 9-8

1) EUROPE

CZECHIA / SLOVAKIA:

►TEVESO S.R.O.

Skroupova 441
CS-50002 HRADEC KRALOVE
CZECHIA
Tel.: +42 049 / 5217 127,
Fax: +42 049 / 5217 226
E-mail: motory@teveso.cz
Website: www.teveso.cz
Contact persons: Ing. Jiri Samal

SWEDEN / FINLAND / NORWAY / ESTONIA / LATVIA / LITHUANIA / DENMARK:

►LYCON ENGINEERING AB

Härkeberga, SE-74596 ENKÖPING
SWEDEN
Tel.: +46 (0) 171 / 414039,
E-mail: info@lycon.se
Website: www.aeronord.eu

FRANCE / BELGIUM / LUXEMBURG MONACO:

►MOTEUR AERO DISTRIBUTION

11 Blvd Albert 1
98000 MONACO
Tel.: +377 (0) 93 30 17 40,
Fax: +377 (0) 93 30 17 60
E-mail: mad@libello.com
Website: www.moteuraerodistribution.com
Contact person: Philippe Thys

GERMANY / AUSTRIA / BULGARIA / HUNGARY / LIECHTENSTEIN / ROMANIA / SWITZERLAND / THE NETHERLANDS:

►FRANZ AIRCRAFT ENGINES VERTRIEB GMBH

Am Weidengrund 1a, 83135 Schechen,
GERMANY
Tel.: +49 (0) 8039 / 90350,
Fax: +49 (0) 8039 / 9035-35
E-mail: info@franz-aircraft.de
Website: www.franz-aircraft.de
Contact person: Eduard Franz

GREAT BRITAIN / IRELAND / ICELAND:

►CFS AEROPRODUCTS LTD.

BUBBENHALL ROAD
BAGINTON, WARWICKSHIRE CV8 3BB
GREAT BRITAIN
Tel.: +44 (0) 2476 / 305 873,
Fax: +44 (0) 2476 / 302 088
E-mail: rotax@cfsaero.com
Website: www.cfsaero.com

SLOVENIA:

►PIPISTREL D.O.O. AJDOVSCINA

Goriska Cesta 50A
5270 AJDOVSCINA
Tel.: +386 (0) 5 / 3663 873,
Fax: +386 (0) 5 / 3661 263
E-mail: info@pipistrel.si
Website: www.pipistrel.si
Contact person: Leon Brecejl

POLAND:

►FASTON LTD.

ul. Zwirki i Wigury 47
PL-21-040 SWIDNIK
Tel.: +48 (0) 81 / 751-2882;
Fax: +48 (0) 81 / 751-5740
E-mail: faston@go2.pl
Contact person: Mariusz Oltarzewski

ITALY / CROATIA / CYPRUS / GREECE / MALTA / PORTUGAL / SPAIN / TUR- KEY / SERBIA:

►LUCIANO SORLINI S.P.A.

Piazza Roma, 1
Carzago di Calvagese Riviera (Brescia)
ITALY
Tel.: +39 030 / 601 033,
Fax: +39 030 / 601 463
E-mail: avio@sorlini.com
Website: www.sorlini.com
Contact person: Alberto Comincioli

2) A M E R I C A

CANADA:

►ROTECH RESEARCH CANADA, LTD.

6235 Okanagan Landing Rd.
VERNON, B.C., V1H 1M5
CANADA

Tel.: +1 250 / 260-6299,

Fax: +1 250 / 260-6269

E-mail: inquiries@rotec.com

Website: www.rotec.com

NORTH / MIDDLE / SOUTH AMERICA:

►KODIAK RESEARCH LTD.

P.O. Box N 658

Bay & Deveaux Street

NASSAU

BAHAMAS

Tel.: +1 242 / 356 5377,

Fax: +1 242 / 356 2409

E-mail: custsupport@kodiakbs.com

Website: www.kodiakbs.com

3) AUSTRALIA / NEW ZEALAND / PAPUA NEW GUINEA:

►BERT FLOOD IMPORTS PTY. LTD.

P.O. Box 61, 16-17 Chris Drive
LILYDALE, VICTORIA 3140
AUSTRALIA

Tel.: +61 (0) 3 / 9735 5655,

Fax: +61 (0) 3 / 9735 5699

E-mail: wal@bertfloodimports.com.au

Website: www.bertfloodimports.com.au

Contact person: Mark Lester

4) A F R I C A

EGYPT:

►AL MOALLA

P.O. Box 7787, ABU DHABI

Tel.: +971 (0) 2/ 444 7378,

Fax: +971 (0) 2/444 6896

E-mail: almoalla@emirates.net.ae

Contact person: Hussain Al Moalla

ALGERIA / MAROCCO / TUNESIA:

►MOTEUR AERO DISTRIBUTION

11 Blvd Albert 1

98000 MONACO

Tel.: +377 (0) 93 30 17 40,

Fax: +377 (0) 93 30 17 60

E-mail: mad@libello.com

Website: www.moteuraerodistribution.com

Contact person: Philippe Thys

LIBYA:

►LUCIANO SORLINI S.P.A.

Piazza Roma, 1

Carzago di Calvagese Riviera (Brescia)

ITALY

Tel.: +39 030 / 601 033,

Fax: +39 030 / 601 463

E-mail: avio@sorlini.com

Website: www.sorlini.com

Contact person: Alberto Comincioli

ANGOLA / BOTSWANA / LESOTHO/ MADAGASCAR / MALAWI / MOZAMBIQUE/ NAMIBIA / SOUTH AFRICA / SWAZILAND/ ZAMBIA / ZIMBABWE:

►AVIATION ENGINES ANDACCESSORIES (PTY) LTD

P.O. Box 15749, Lambton 1414,

SOUTH AFRICA

Tel.: +27 (0) 11 / 824 3368,

Fax: +27 (0) 11 / 824 3339

E-mail: niren@cometaviationsupplies.co.za

Website: www.aviation-engines.co.za

Contact person: Niren Chotoki

GHANA / BENIN / BURKINA FASO / CAMEROON / CENTRAL AFRICAN REPUBLIC / CONGO / GABON / GUINEA / IVORY COAST / MALI / MAURITANIA / NIGER/ NIGERIA / SENEGAL / TOGO:

►WAASPS LTD

PMB KA49, Kotoka International Airport, Accra

GHANA

Tel.: +233 (0) 28 5075254,

Fax: +233 (0) 217 717 92

E-mail: info@waasps.com

Website: www.waasps.com

Contact person: Jonathan Porter

5) A S I A

CHINA / HONG KONG / MACAO:

►PEIPOINT INDUSTRIES LTD.

Rm. 1302, Westlands Centre
20 Westlands Road, Quarry Bay
HONG KONG
Tel.: +852 (0) 2885 / 9525,
Fax: +852 (0) 2886 / 3241
E-mail: admin@peiport.com.hk
Website: www.peiport.com
Contact person: Larry Yeung

CIS:

►AVIAGAMMA JSCO.

P.O. Box 51, 125 057 MOSCOW
Tel.: +7 499 / 158 31 23,
Fax: +7 499 / 158 62 22
E-mail: aviagamma@mtu-net.ru
Website: www.aviagamma.ru
Contact person: Vladimir Andriytschuk
General Director

KOREA:

►KOREA BUSINESS AIR SERVICE CO. LTD.

672-4 KBAS Bldg. Deungchon-dong,
Kangseo-ku, Seoul, South Korea
Tel.: +82 (0) 2 / 3664 - 6644
Fax: +82 (0) 2 / 2658 - 6562
E-mail: sd.lim@kbas.com
Website: www.kbas.com
Contact person: Su Dong Lim

INDONESIA / MALAYSIA / PHILIP- PINES / SINGAPORE / THAILAND / TAIWAN:

►BERT FLOOD IMPORTS PTY. LTD.

P.O. Box 61, 16-17 Chris Drive LILYDALE,
VICTORIA 3140
AUSTRALIA
Tel.: +61 (0) 3 / 9735 5655,
Fax: +61 (0) 3 / 9735 5699
E-mail: wal@bertfloodimports.com.au
Website: www.bertfloodimports.com.au
Contact person: Mark Lester

UNITED ARAB. EMIRATES:

►AL MOALLA

P.O. Box 7787
ABU DHABI
Tel.: +971 (0) 2 / 444 7378,
Fax: +971 (0) 2 / 444 6896
E-mail: almoalla@emirates.net.ae
Contact person: Hussain Al Moalla

ISRAEL/ PAKISTAN:

►LUCIANO SORLINI S.P.A.

Piazza Roma, 1
Carzago di Calvagese Riviera (Brescia),
ITALY
Tel.: +39 030 / 601 033,
Fax: +39 030 / 601 463
E-mail: avio@sorlini.com
Website: www.sorlini.com
Contact person: Alberto Comincioli

JAPAN :

►JUA, LTD.

1793 Fukazawa, Gotemba City
SHIZUOKA PREF 412
Tel.: +81 (0) 550 / 83 8860,
Fax: +81 (0) 550 / 83 8224
E-mail: jua@shizuokanet.ne.jp
Contact person: Yoshihiko Tajika
President

INDIA:

►VARMAN AVIATION PVT. LTD.

Aviation Complex, 16-17
EPIP, Whitefield
BANGALORE - 560066
Tel.: +91 (0) 80 / 28412536, 28412655,
28412656
Fax: +91 (0) 80 / 28413559
E-mail: varman@blr.vsnl.net.in
Website: www.varman.com
Contact person: M. M. Varman

ROTAX[®]
AIRCRAFT ENGINES



www.abm.at

Motornummer / Engine serial no.

Flugzeugtype / Type of aircraft

Flugzeugkennzeichen / Aircraft registration no.

ROTAX® Vertriebspartner

ROTAX® authorized distributor

WWW.FLYROTAX.COM